



MODEL 680SS

OPERATING INSTRUCTIONS AND PARTS MANUAL

Read instructions carefully before attempting to assemble, install, operate or service this pressure washer. Failure to comply with instructions could result in personal injury and/or property damage!

SPECIFICATIONS

- Pump Volume At Pump Head: 3.0 GPM/180 GPH
- Pump Pressure At Pump Head: 1000 PSI
- Burner Type: Fuel Oil Fired, 289,900 BTU/Hr.
- Burner Fuel Pressure: 200 PSI Max.
- Machine Voltage: 120VAC/60Hz/1Ph
- Total Machine Amperage: 20 Amps
- Machine Weight: 332 Lbs.
- Shipping Weight: 367 Lbs.
- Exhaust Stack Size: 8"
- Machine Dimensions: Length = 44", Width = 26", Height = 41"



Output specifications are based on engine power curves at 100 meters above sea level and 25° C ambient temperature in accordance with SAE J1349.



SERIAL NUMBER:	
DATE PURCHASED:	
FOR SALES AND SERVICE, PLEASE CONTACT:	

CONTENTS

Important Safety Information	4-6
Component Identification	7
Assembly Instructions	8
Installation Instructions	9
Operation Instructions	10
General Washing Techniques & Storage	11
Maintenance	12
Troubleshooting	13-14
Exploded Views	15-16
Exploded View Parts List	17
Burner Assembly Exploded View & Parts List	18
Crossfire Burner Exploded View & Parts List	19-20
Fuel Tank Assembly & Parts List	21
Control Panel Assembly & Parts List	22
Coil Outlet Assembly & Parts List	23
Hose, Gun & Wand Assembly & Parts List	24
Pump Assembly & Parts List	25
Pump, Exploded View & Parts List	25-26
VBA Unloader Exploded View & Parts List	27
Wiring Diagram	28

Model Number _____

Serial Number _____

Date of Purchase _____

The model and serial numbers will be found on a decal attached to the pressure washer. You should record both serial number and date of purchase and keep in a safe place for future reference.

INTRODUCTION & IMPORTANT SAFETY INFORMATION

Thank you for purchasing this Pressure Washer.

We reserve the right to make changes at any time without incurring any obligation.

Owner/User Responsibility:

The owner and/or user must have an understanding of the manufacturer's operating instructions and warnings before using this pressure washer. Warning information should be emphasized and understood. If the operator is not fluent in English, the manufacturer's instructions and warnings shall be read to and discussed with the operator in the operator's native language by the purchaser/owner, making sure that the operator comprehends its contents.

Owner and/or user must study and maintain for future reference the manufacturers' instructions.

The operator must know how to stop the machine quickly and understand the operation of all controls. Never permit anyone to operate the engine without proper instructions.

SAVE THESE INSTRUCTIONS

This manual should be considered a permanent part of the machine and should remain with it if machine is resold.

When ordering parts, please specify model and serial number. Use only identical replacement parts.

This machine is to be used only by trained operators.

IMPORTANT SAFETY INFORMATION

WARNING



READ OPERATOR'S MANUAL THOROUGHLY PRIOR TO USE.

WARNING: To reduce the risk of injury, read operating instructions carefully before using.

1. Read the owner's manual thoroughly. Failure to follow instructions could cause malfunction of the machine and result in death, serious bodily injury and/or property damage.
2. Know how to stop the machine and bleed pressure quickly. Be thoroughly familiar with the controls.
3. Stay alert — watch what you are doing.
4. All installations must comply with local codes. Contact your electrician, plumber, utility company or the selling distributor for specific details. If your machine is rated 250 volts or less, single phase will be provided with a ground fault circuit interrupter (GFCI). If rated more than 250 volts, or more than single phase this product should only be connected to a power supply receptacle protected by a GFCI.

DANGER: Improper connection of the equipment-grounding conductor can result in a risk of electrocution. Check with a qualified electrician or service personnel if you are in doubt as to whether the outlet is properly grounded. Do not modify the plug provided with the product - if it will not fit the outlet, have a proper outlet installed by a qualified electrician. Do not use any type of adaptor with this product

WARNING



KEEP WATER SPRAY AWAY FROM ELECTRICAL WIRING.

WARNING: Keep wand, hose, and water spray away from electric wiring or fatal electric shock may result.

5. To protect the operator from electrical shock, the machine must be electrically grounded. It is the responsibility of the owner to connect this machine to a UL grounded receptacle of proper voltage and amperage ratings. Do not spray water on or near electrical components. Do not touch machine with wet hands or while standing in water. Always disconnect power before servicing.

WARNING



RISK OF EXPLOSION: OPERATE ONLY WHERE OPEN FLAME OR TORCH IS PERMITTED

WARNING: Flammable liquids can create fumes which can ignite, causing property damage or severe injury.

WARNING: Risk of explosion — Operate only where open flame or torch is permitted.

6. In oil burning models, use only kerosene, No. 1 home heating fuel, or diesel. If diesel is used, add a soot remover to every tankful.

WARNING



RISK OF FIRE. DO NOT ADD FUEL WHEN OPERATING MACHINE.

WARNING: Risk of fire — Do not add fuel when the product is operating or still hot.

WARNING: Do not use gasoline crankcase draining or oil containing gasoline, solvents or alcohol. Doing so will result in fire and/or explosion.

7. Oil burning appliances shall be installed only in locations where combustible dusts and flammable gases or vapors are not present. Do not store or use gasoline near this machine.
8. Do not allow acids, caustic or abrasive fluids to pass through the pump.
9. Never run pump dry or leave spray gun closed longer than 1-2 minutes.
10. Keep operating area clear of all persons.

IMPORTANT SAFETY INFORMATION

! WARNING



USE PROTECTIVE EYE WEAR AND CLOTHING WHEN OPERATING THIS EQUIPMENT.

WARNING: High pressure spray can cause paint chips or other particles to become airborne and fly at high speeds. To avoid personal injury, eye, hand and foot safety devices must be worn.

11. Eye, hand, and foot protection must be worn when using this equipment.

! WARNING



EAR PROTECTION MUST BE WORN

WARNING: This machine exceeds 85 db appropriate ear protection must be worn.

! WARNING



HOT DISCHARGE FLUID: DO NOT TOUCH OR DIRECT DISCHARGE STREAM AT PERSONS.

WARNING: Hot discharge fluid. Do not touch or direct discharge stream at persons.

WARNING: This machine produces hot water and must have insulated components attached to protect the operator.

! WARNING



RISK OF INJURY: HOT SURFACES CAN CAUSE BURNS

WARNING: Risk of injury. Hot surfaces can cause burns. Use only designated gripping areas of spray gun and wand. Do not place hands or feet on non-insulated areas of the pressure washer.

12. To reduce the risk of injury, close supervision is necessary when a machine is used near children. Do not allow children to operate the pressure washer. **This machine must be attended during operation.**

! WARNING



TRIGGER GUN KICKS BACK - HOLD WITH BOTH HANDS

WARNING: Grip cleaning wand securely with both hands before starting. Failure to do this could result in injury from a whipping wand.

13. Never make adjustments on machine while in operation.

14. Be certain all quick coupler fittings are secured before using pressure washer.

! WARNING



RISK OF INJECTION OR SEVERE INJURY TO PERSONS. KEEP CLEAR OF NOZZLE.

WARNING: High pressure developed by these machines will cause personal injury or equipment damage. Keep clear of nozzle. Use caution when operating. Do not direct discharge stream at people, or severe injury or death will result.

! WARNING



PROTECT FROM FREEZING

WARNING: Protect machine from freezing.

15. To keep machine in best operating conditions, it is important you protect machine from freezing. Failure to protect machine from freezing could cause malfunction of the machine and result in death, serious bodily injury, and/or property damage. Follow storage instructions specified in this manual.

16. Inlet water must be clean fresh water and no hotter than 90°F.

! WARNING



RISK OF ASPHYXIATION: USE THIS PRODUCT ONLY IN A WELL VENTILATED AREA.

WARNING: Risk of asphyxiation. Use this product only in a well ventilated area.

17. Avoid installing machines in small areas or near exhaust fans. Adequate oxygen is needed for combustion or dangerous carbon monoxide will result.

18. Manufacturer will not be liable for any changes made to our standard machines or any components not purchased from us.

19. The best insurance against an accident is precaution and knowledge of the machine.

! WARNING



RISK OF INJURY FROM FALLS WHEN USING LADDER.

WARNING: Be extremely careful when using a ladder, scaffolding or any other relatively unstable location. The cleaning area should have adequate slopes

IMPORTANT SAFETY INFORMATION

and drainage to reduce the possibility of a fall due to slippery surfaces.

20. Do not overreach or stand on unstable support. Keep good footing and balance at all times.

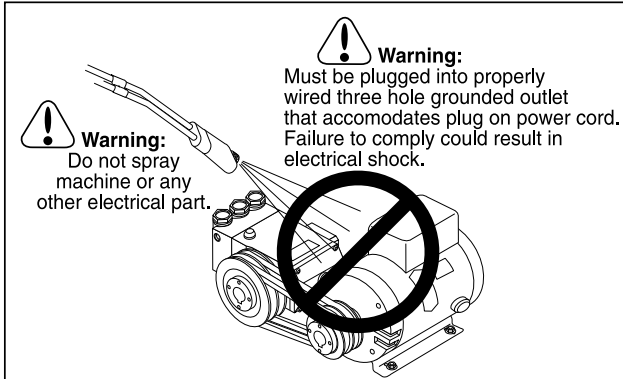

21. Do not operate this machine when fatigued or under the influence of alcohol, prescription medications, or drugs.



Follow the maintenance instructions specified in the manual.

COMPONENT IDENTIFICATION

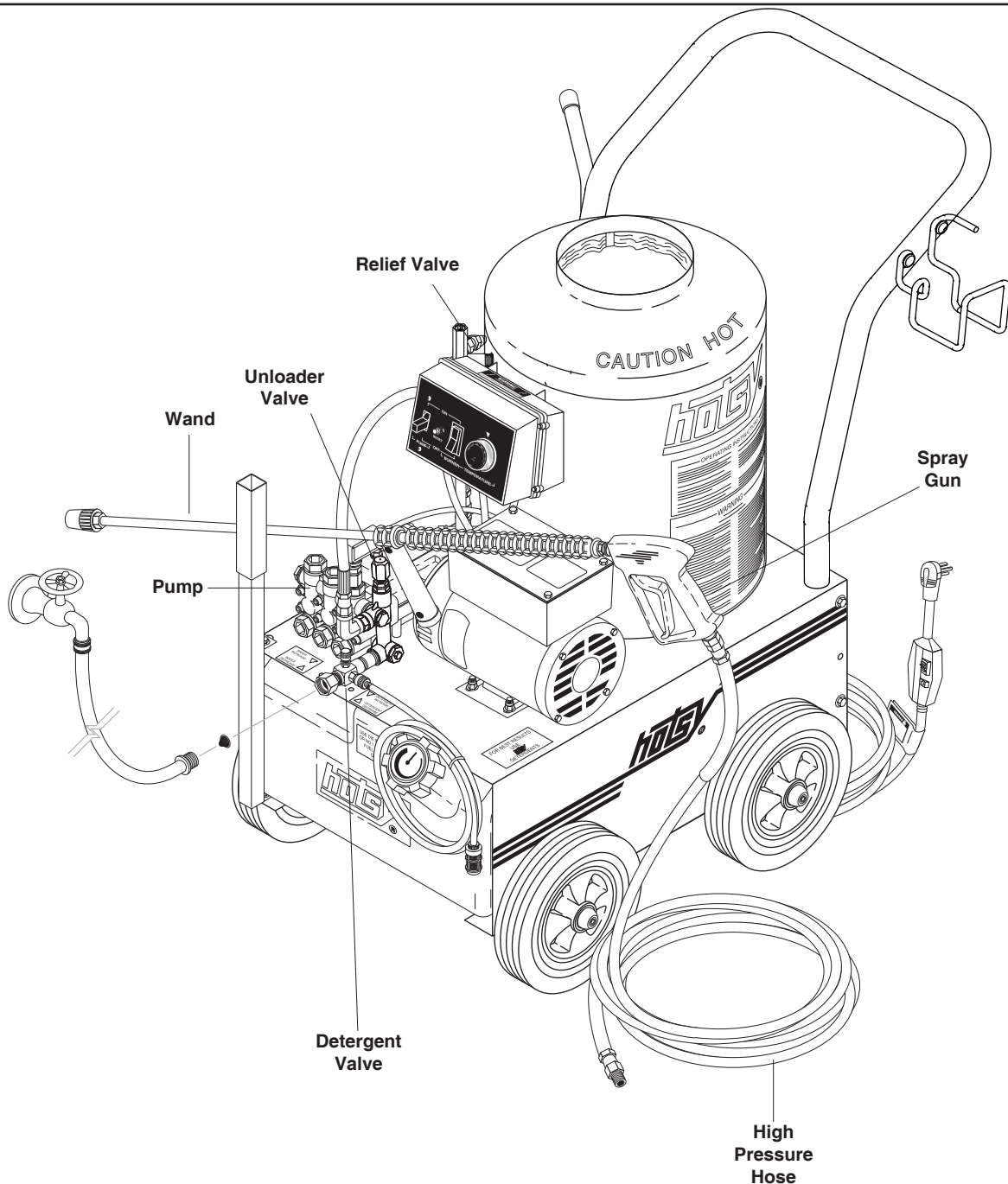

Pump — Delivers a specific gpm to the high pressure nozzle which develops pressure.

Spray Gun — Controls the application of water and detergent onto cleaning surface with trigger device. Includes safety latch.

Detergent Valve — Allows you to siphon and mix detergents.

Wand — Must be connected to the spray gun.

High Pressure Hose — Connect one end to water pump high pressure discharge nipple and the other end to spray gun.

Relief valve — Secondary pressure release in the unlikely event the unloader valve fails.

Unloader Valve — Safety device which, when the spray gun closes, prevents over pressurization.

Note: If trigger on spray gun is released for more than 2 minutes, water will leak from the pump protector. Warm water will discharge from pump protector onto floor. This system prevents internal pump damage.

ASSEMBLY INSTRUCTIONS

Unpacking

Unpack carefully. Wear safety glasses or goggles while unpacking, assembling or operating pressure washer. If there are missing components or hidden damage immediately contact distributor or carrier concerning discrepancies.

1. Cut strapping band from pressure washer and pallet.
2. Remove pressure washer from pallet.

Parts Included

- Pressure Washer
- Pressure Hose
- Hose Hanger
- Wand
- Wheels (4 Ea.)
- Axles (2 Ea.)
- Handle
- Parts Bag Containing:
 - Bolts 5/16" x 1-1/2" (5 Ea.)
 - Vinyl Cap
 - Nuts 5/16" (5 Ea.)
 - Washers 5/8" (10 Ea.)
 - Pressure Nozzle
 - Hubcaps (4 Ea.)
 - Spring Washers (4 Ea.)
 - Quick Disconnect
 - Quick Disconnect Plug
 - Trigger Gun
 - GFCI Cord Hanger
- Operating Instructions and Parts Manual

Tools Required

- 10" Adjustable Crescent Wrenches (2 Ea.)
- 11/16" Socket
- Hammer
- 7/16" Open End Wrench
- Teflon Tape

Pressure Hose and Wand

1. When assembling, use teflon tape on all plumbing connections to prevent leakage.
2. Install pressure hose on machine as shown in **Figure 2**.

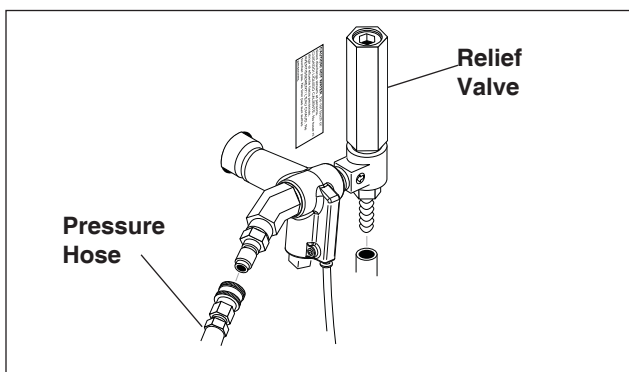

Figure 2 - Pressure Hose Installation

IMPORTANT: Before installing pressure hose onto the trigger gun/wand assembly, turn on the water supply and allow water to run from the end of the hose until clear to prevent the nozzle from clogging.

3. Assemble wand components as shown in **Figure 3**. Connect pressure hose to trigger gun.
4. Make sure that all plumbing connections are tight.

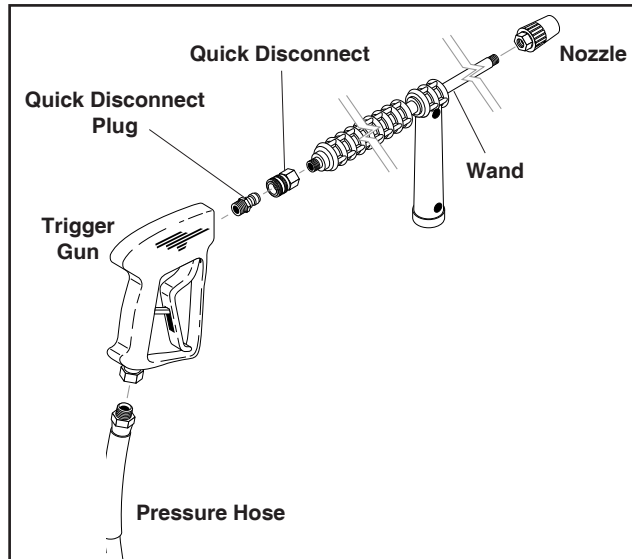

Figure 3 - Wand Components

INSTALLATION INSTRUCTIONS

Getting Started

IMPORTANT: Proper initial installation of equipment will assure more satisfactory performance, longer service life, and lower maintenance cost.

IMPORTANT: The use of a backflow preventer on the water supply hose is recommended and may be required by local code.

The pressure washer should be run on a level surface and in a protected area where it is not readily influenced by outside forces such as strong winds, freezing temperatures, rain, etc. The pressure washer should be located to assure easy access for filling of fluids, adjustments and maintenance. Normal precautions should be taken by the operator to prevent moisture from reaching the pressure washer. It is recommended that a partition be made between the wash area and the pressure washer to prevent direct spray from the wand from coming in contact with the pressure washer. Moisture reaching the equipment will reduce the pressure washer's service life. All installations must comply with the local codes covering such installations.

INSTALLATION INSTRUCTIONS

Venting

CAUTION: All venting must be in accordance with applicable federal and state laws, and local ordinances. Consult local heating contractors.

If the pressure washer is to be used in an enclosed area, a flue must be installed to vent burner exhaust to the outside atmosphere. Be sure the flue is the same size as the burner exhaust vent on the pressure washer lid. Poor draft will cause the pressure washer to soot and not operate properly. When selecting the location for installation, beware of poorly ventilated locations or areas where exhaust fans may cause an insufficient supply of oxygen. Proper combustion can only be obtained when there is a sufficient supply of oxygen available for the amount of fuel being burned. If it is necessary to install the machine in a poorly ventilated area, outside fresh air may have to be piped to the burner and a fan installed to bring sufficient air into the machine. Locate the pressure washer so that the flue will be as straight as possible and protrude through the roof at a proper height and location to provide adequate draft. This oil fired pressure washer must have a draft regulator installed in the flue (available from most heating contractors). A draft regulator will permit proper upward flow of exhaust flue gases.

Beckett Oil Burner

Burner Air Adjustment: The oil burner is preset for operation at altitudes below 1000 feet. If operated at higher altitudes, it may be necessary to adjust the air band setting. Adjust the air band for a #1 or #2 smoke spot on the Bacharach scale.

To adjust, start machine and turn burner ON (refer to **Operation** for details). Loosen two locking screws found in the air shutter openings (refer to **Figure 4**) and close air shutter until black smoke appears from burner exhaust vent. Note air band position. Next, slowly open the air shutter until white smoke just starts to appear. Turn air shutter halfway back to the black smoke position previously noted. Tighten locking screws.

If the desired position cannot be obtained using only the air shutter, lock the air shutter in as close a position as can be obtained, then repeat the above procedure on the air band setting.

CAUTION: If white smoke appears from burner exhaust vent during start-up or operation, discontinue use and readjust air bands.

NOTE: If a flue is installed, have a professional serviceman adjust your burner for a #1 or #2 smoke spot on the Bacharach scale.

For additional burner component information, see **Burner Assembly**. It is recommended that the oil burner be serviced yearly or as needed. Contact your local service center.

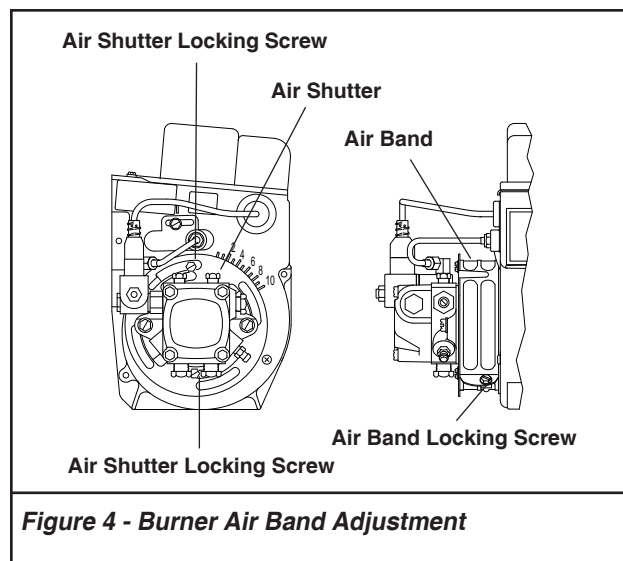

Figure 4 - Burner Air Band Adjustment

Crossfire Oil Burner

Burner Air Adjustment: The oil burner on this machine is preset for operation at altitudes below 1000 feet. If operated at higher altitudes, it may be necessary to adjust the air band for a #1 or #2 smoke spot on the Bacharach scale.

To adjust, start machine and turn burner ON. Loosen two locking screws found on the air band and close air band until black smoke appears from burner exhaust vent. Note air band position. Next, slowly open the air band until white smoke just starts to appear. Turn air band halfway back to the previously noted position. Tighten locking screws.

Burner Air Adjustment

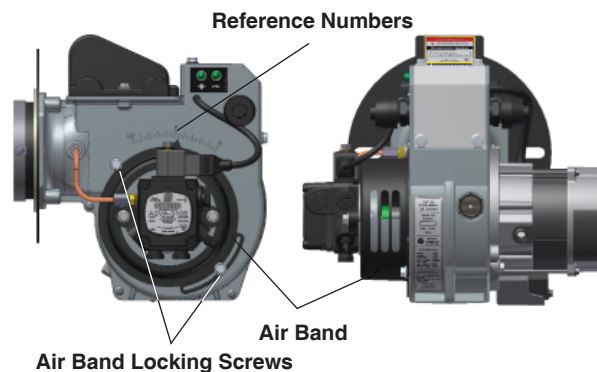

CAUTION: If white smoke appears from burner exhaust vent during start-up or operation, discontinue use and readjust air bands.

NOTE: If a flue is installed, have a professional serviceman adjust your burner for a #1 or #2 smoke spot on the Bacharach scale.

OPERATION INSTRUCTIONS

Before Starting

WARNING: Check hoses, trigger guns, fittings, and fuel connections daily for signs of wear, cracks and looseness, and replace as required.

1. Connect water supply hose to the standard garden hose connector. The water faucet and supply hose must be capable of providing 3.0 GPM at 20 to 80 PSI.
2. Fill fuel tank. Use kerosene, #1 grade home heating oil, #1 or #2 diesel fuel. **DO NOT USE GASOLINE.**
3. Check pump oil level.
4. If detergents are to be used, only use detergents intended for pressure washers. Follow instructions on the detergent container.

Electrical Connections

WARNING: Make sure all switches and controls are in the OFF position prior to plugging in.

CAUTION: This cleaner is equipped with a UL approved ground fault circuit interrupter (GFCI) power cord. Use UL grounded type receptacles of proper voltage and amperage ratings. Where a properly grounded receptacle is not available, it is the personal responsibility of the owner to have one installed. Always disconnect power before servicing your cleaner.

Connect electrical cord and test the GFCI using the reset and test procedures conveniently located on the GFCI device. The GFCI must be reset and tested with every use. Do not use machine if the GFCI device fails test.

To Start

IMPORTANT: The water must be turned on before starting. Running the pump dry will cause damage and void warranty.

IMPORTANT: Do not allow the machine to run in bypass for more than 10 minutes at any one time or damage to pump may occur.

1. Turn water on.
2. Hold trigger gun firmly, squeeze trigger and turn pump switch ON. Allow air to purge from system.
3. If HOT water is desired, turn burner switch ON. Adjust thermostat to desired temperature. The burner will fire immediately with a small puff of smoke. If smoke continues refer to the **Troubleshooting Guide** in this manual. When the trigger gun is closed or temperature setting is reached, the burner will automatically turn off.

To Stop

1. If detergents were used, draw clear water through the detergent line to purge detergent.
2. If burner was used, turn off burner switch and allow pump to run cold water through coil.
3. Turn OFF pump switch.
4. Turn OFF water supply.
5. Squeeze trigger gun open to relieve system pressure.

NOTE: If the machine is unplugged from receptacle, you must reset the GFCI power cord when machine is plugged in. Always test GFCI before each use. See instructions in the Electrical Connections section of this manual.

GENERAL CLEANING TECHNIQUES & STORAGE

Pre-rinse cleaning surface with fresh water. Place detergent suction tube directly into cleaning solution and apply to surface at low pressure (for best results, limit your work area to sections approximately 6 feet square and always apply detergent from bottom to top). Allow detergent to remain on surface 1-3 minutes. Do not allow detergent to dry on surface. If surface appears to be drying, simply wet down surface with fresh water. If needed, use brush to remove stubborn dirt. Rinse at high pressure from top to bottom in an even sweeping motion keeping the spray nozzle approximately 1 foot from cleaning surface. Use overlapping strokes as you clean and rinse any surface. For best surface cleaning action spray at a slight angle.

Recommendations:

- Before cleaning any surface, an inconspicuous area should be cleaned to test spray pattern and distance for maximum cleaning results.
- If painted surfaces are peeling or chipping, use extreme caution as pressure washer may remove the loose paint from the surface.
- Keep the spray nozzle a safe distance from the surface you plan to clean. High pressure wash a small area, then check the surface for damage. If no damage is found, continue to pressure washing.



CAUTION - Never use:

- Bleach, chlorine products and other corrosive chemicals
- Liquids containing solvents (i.e., paint thinners, gasoline, oils)
- Tri-sodium phosphate products
- Ammonia products
- Acid-based products

These chemicals will harm the machine and will damage the surface being cleaned.

RINSING

It will take a few seconds for the detergent to clear. Apply safety latch to spray gun. Select and install desired high pressure nozzle. **NOTE:** You can also stop detergent from flowing by removing detergent siphon tube from bottle.

STORAGE

DANGER: DO NOT store flammable liquids (gasoline, diesel fuel, solvents, etc.) near pressure washer, or in non-ventilated areas.

Protect from freezing by storing in a heated area, or by flushing the system with antifreeze (use an automotive engine antifreeze or windshield washer solvent to antifreeze). To flush the system fill the float tank with antifreeze and remove pressure nozzle from wand. Start the machine and allow it to run until antifreeze flows from the end of the wand. Place end of wand into float tank and circulate the antifreeze through system for several minutes. Squeeze and release the trigger of the trigger gun several times to antifreeze the unloader system. Also draw antifreeze through the detergent inlet line to antifreeze the detergent system. For added protection after anti-freezing, disconnect the pressure hose from machine and remove the coil drain plug (refer to **Figure 12** Item 15 for location). After coil has drained, replace pressure hose and coil drain plug. If the pressure washer is not to be used for an extended length of time, it is recommended that the system be flushed with antifreeze for rust protection.

MAINTENANCE

WARNING: Unauthorized machine modification or use of non-approved replacement parts may cause personal injury and/or property damage and will void the manufacturer warranty.

Pump

Lubrication: To lubricate pump, use 30W non-detergent oil for pump crankcase. Crankcase must be filled to center of sight glass window found on the rear of the pump, refer to **Figure 5**. During the break-in-period, make sure the oil is changed after the first 25 hours of operation. After that, replace oil every 3 months or 300 hours of operation, whichever comes first.

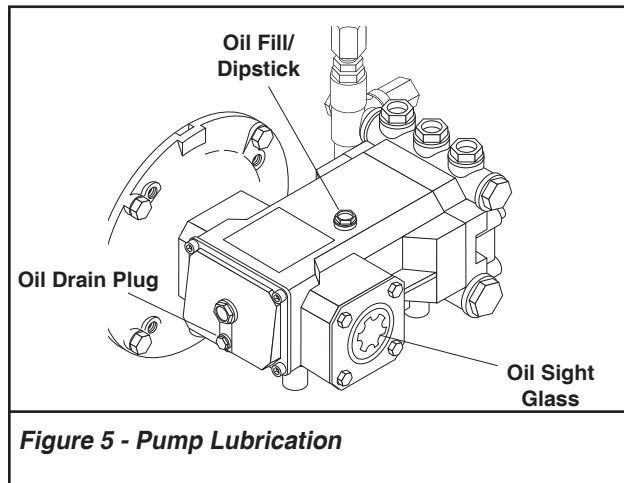

Figure 5 - Pump Lubrication

Proper Pump Care:

- Do not pump acids.
- Do not allow pump to run dry.
- Winterize if storing in freezing temperatures, refer to **Storage** for details.
- Use a water softener on the water system if known to be high in mineral content.
- Use only high quality detergents and follow mix recommendations.
- Flush the system with clear water immediately after using detergent solutions.
- Clean filter screen on detergent inlet line periodically.
- Flush the pressure washer system with antifreeze if storing for an extended period of time, refer to **Storage** to details.

Pump Motor

On a yearly basis, oil pump motor per instructions on motor nameplate.

NOTE: Some motors may be equipped with permanently lubricated bearings and will not require additional lubrication.

Relief Valve

WARNING: The relief valve on this pressure washer has been factory set and sealed and is a field non-adjustable part. Tampering with the factory setting may cause personal injury and/or property damage, and will void the manufacturer warranty. For replacement parts refer to **Coil Outlet Assembly**.

If pressure from pump or thermal expansion should exceed safe limits, the relief valve will open, allowing high pressure to be discharged through hose to ground. **Caution: Inspect relief valve annually for any obstruction.**

Unloader Valve

WARNING: The unloader valve on this pressure washer has been factory set and sealed and is a field nonadjustable part. Tampering with the factory setting may cause personal injury and/or property damage, and will void the manufacturer warranty. For replacement refer to **Pump Assembly, Item 4**.

Burner Fuel Filter

Drain any water which has accumulated in fuel filter and clean or replace filter element as needed. Refer to **Burner Assembly**.

Heating Coil

Coil Descaling: In hard water areas, scale buildup within the heating coil will occur. Scale deposits will decrease the water temperature rise and may eventually clog the heating coil. Contact your local service center when descaling is needed.

Coil Desooting: Poor grades of fuel oil or inadequate combustion air will cause heavy soot buildup on the outside surface of the heating coil. These deposits will insulate the coil. This will restrict the air flow through the coil, further aggravating the soot buildup. Contact your local service center when desooting is needed.

TROUBLESHOOTING

SYMPTOM	POSSIBLE CAUSES	CORRECTIVE ACTION
PUMP MOTOR WILL NOT RUN	GFCI tripped	Reset and test GFCI with every use. Follow Instructions under Operation .
	No voltage to machine	Test power supply and correct.
	Pump motor reset button (thermal overload protector) tripped	Push reset button on control box. If tripped, check for proper voltage or clogged water nozzle.
	Excessive pressure due to clogged water nozzle	Clean water nozzle.
NO WATER SPRAYS FROM WATER NOZZLE	Water nozzle completely clogged	Clean water nozzle.
	Inlet water screen clogged	Check screen and clean if necessary.
	Pump sucking air	Fill the detergent container and check for loose hose clamps or fittings.
LOW PRESSURE FROM WATER NOZZLE	Inlet water screen clogged	Check screen and clean if necessary.
	Water nozzle worn or incorrect size	Replace nozzle with proper size.
	Water supply low	Correct water supply.
	Pump sucking air	Fill the detergent container and check for loose hose clamps or fittings.
POOR OR NO DETERGENT FLOW	Low detergent level	Fill the detergent container.
	Detergent screen clogged	Clean if necessary.
	Detergent valve not opening	Check that handle or knob is not slipping on shaft.
	Water nozzle clogged	Clean water nozzle.
	Excessive inlet pressure (more than 80 PSI)	Install pressure regulator on the inlet line.
BURNER WILL NOT IGNITE WHEN TRIGGER GUN IS OPEN	Defective pressure switch	Replace pressure switch.
	No fuel	Fill fuel tank with proper fuel.
	Fuel valve closed	Check that fuel valve on fuel tank is open.
	Thermostat set too low	Raise thermostat setting.
	Burner motor reset button (thermal overload protector) tripped	Push reset button on burner motor. If tripped, check for proper voltage.
	Clogged fuel filter	Clean fuel filter.
BURNER SMOKES OR HAS OBNOXIOUS ODOR	Air intake adjustment needs to be adjusted	Readjust air intake per the oil burner section of this manual.
	Improper fuel	Use proper fuel.

TROUBLESHOOTING

IMPORTANT

If the pressure washer demonstrates other symptoms or the corrective actions listed do not correct the problem, contact the local authorized Hotsy Service Center. The Hotsy Service Center can be identified by visiting www.hotsy.com.

When ordering from your dealer, please provide the following:

Model Number: 680SS

Machine Serial Number: _____

Component Part Number: _____

Description: _____

EXPLODED VIEW - LEFT

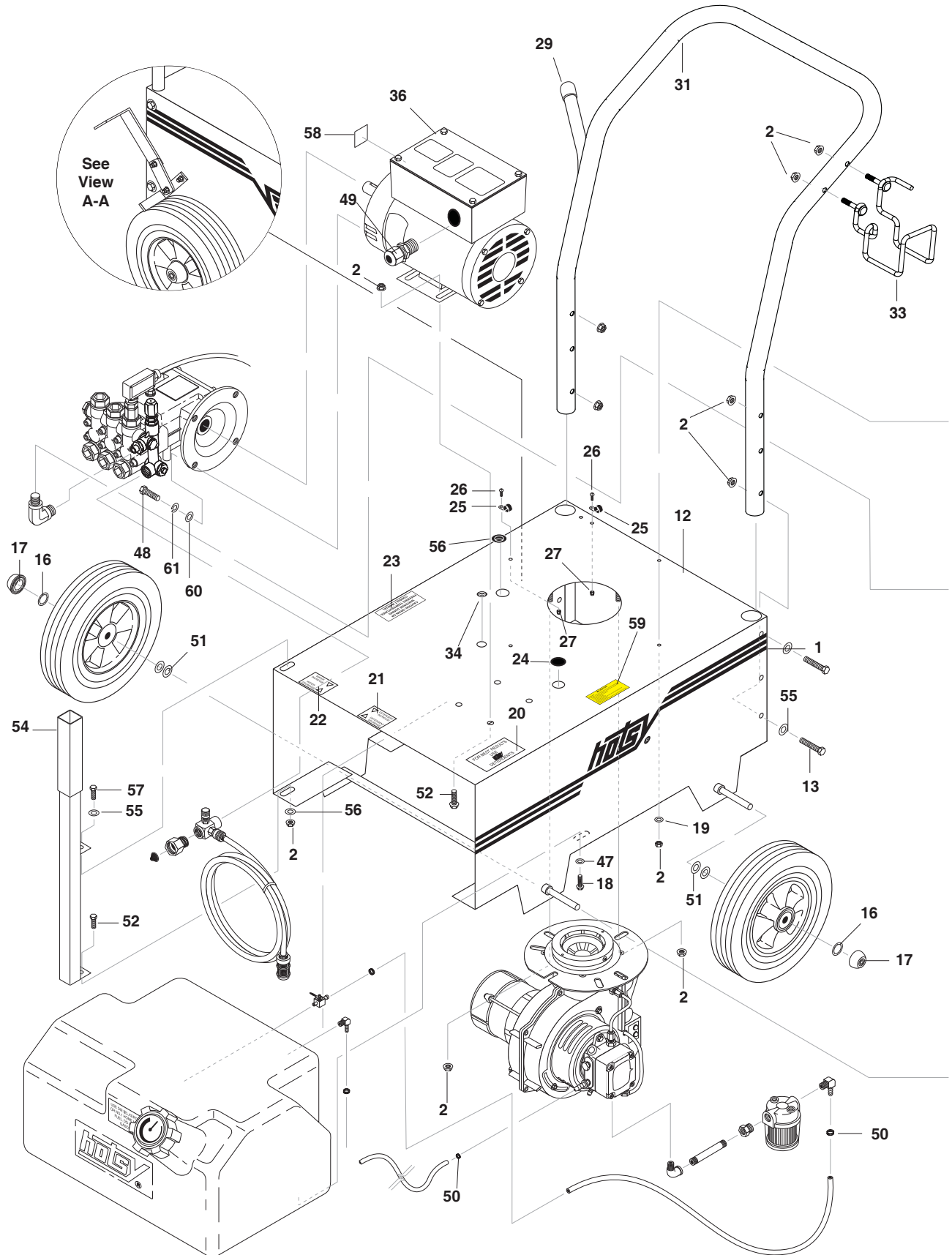

EXPLODED VIEW - RIGHT

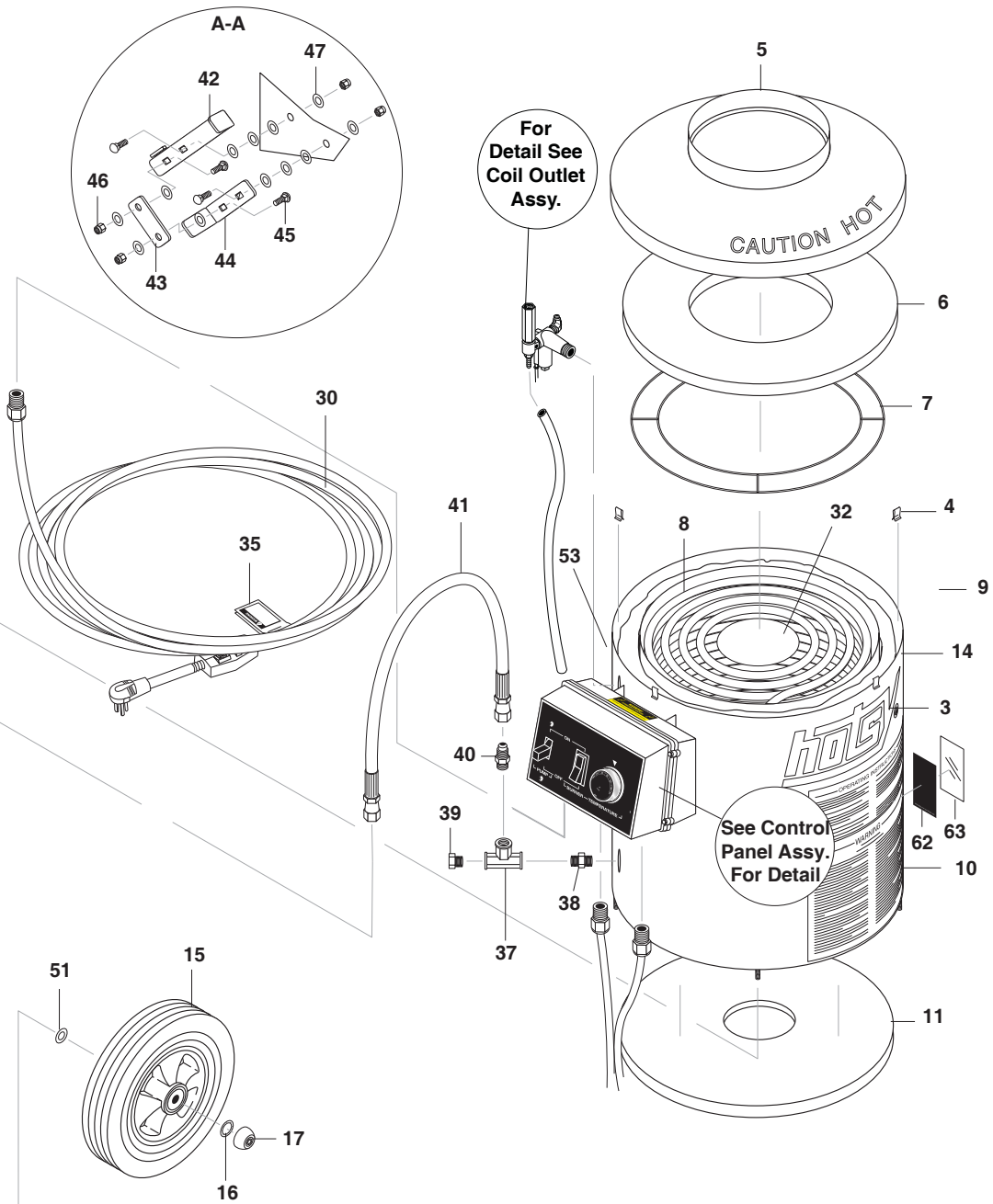

EXPLODED VIEW PARTS LIST

ITEM	PART NO.	DESCRIPTION	QTY	ITEM	PART NO.	DESCRIPTION	QTY
1	8.901-106.0	Label, Hotsy Logo Stripe	2	41	8.918-425.0	Hose, 3/8" x 29", 2 Wire, Pressure Loop	1
2	9.802-778.0	Nut, 5/16" Whiz Loc Flange	16	42	8.912-017.0	Lever, Brake, Red	1
3	8.704-654.0	Label, Hotsy logo Red	2	43	8.912-020.0	Linkage, Brake, Red	1
4	9.802-825.0	Clip, Retaining U-Type	4	44	8.912-019.0	Bracket, Brake Pad, Red	1
5	8.719-913.0	Top Hat, Weld Assy, 16"	1	45	9.802-705.0	Bolt, 1/4"-20 x 1" Carriage Zinc	4
6	9.802-904.0	Insulation, Top Head, 16 Od x 8.0 Id, Fiberglass	1	46	9.802-773.0	Nut, 1/4-20 Esna Nc	4
7	9.803-108.0	Insulation Retaining Ring	1	47	9.802-802.0	Washer, 1/4" Flat Sae Zinc	14
8	8.717-438.0	Insulation Blanket 22.5 x 52	1	48	9.802-720.0	Bolt, 3/8" x 1", Nc Hh	4
9	8.719-946.0	Hanger, Hose	1	49	8.752-969.0	Strain Relief, Lt, Str, 1/2 Npt	1
10	8.900-894.0	Label, Operating/Warning	1	50	6.390-126.0	Clamp, Hose, .46-.54 St	2
11	9.802-903.0	Insulation, Bottom, 16 Od x 4.5	1	51	9.802-810.0	Washer, 5/8", Flat, Sae Zinc	4
12	8.911-832.0	Frame, Welded Assy Hotsy	1	52	8.718-625.0	Bolt, 5/16"-18 x 3/4", Nc Carriage Zinc	5
13	9.802-716.0	Bolt, 5/16 x 2", Nc Hh	4	53	9.800-021.0	Label, Hot Water Outlet	1
14	8.911-804.0	Outer Wrap Assy	1	54	8.911-807.0	Bracket, Hose Reel Mount	1
15	9.802-274.0	Wheel & Tire Hard Rubber	4	55	8.718-980.0	Washer, 5/16" Flat, Sae	5
16	8.718-870.0	Nut, .61 Id, Push Flat	4	56	9.802-104.0	Bushing, 1" Snap	1
17	9.182-506.0	Cap Blk Plastic 5/8" Fastener	4	57	8.718-618.0	Bolt, 5/16-18 x 3/4", Hh Gr Cs Zinc	1
18	9.802-754.0	Screw, 1/4" x 1/2" Nc, Whiz Loc Flange	2	58	9.800-032.0	Label, Motor Overload Reset	1
19	8.719-000.0	Washer, 5/16" x 1-1/4", Fender, Sae	3	59	9.800-049.0	Label, Manufacturers Cleaning Solution	1
20	8.901-136.0	Label, Use Hotsy Detergent	1	60	9.802-807.0	Washer, 3/8" Sae, Flat, Zinc	4
21	8.901-124.0	Label, Water Metering	1	61	9.802-814.0	Washer, 3/8" Split Lock Zinc	4
22	8.901-125.0	Label, Detergent Metering	1	62	8.932-968.0	Label, Intended for Outdoor Use1	
23	8.901-135.0	Label, Caution Winterize	1	63	9.800-034.0	Label, Clear Lexan	1
24	8.706-744.0	Plug, Plastic 1"	1				
25	8.709-090.0	Clamp, Wire/Tube, 0.750D	2				
26	8.718-588.0	Screw, 10-24" x 1/2", Ph, Ms	2				
27	8.718-863.0	Nut, 10-24, Esna, Nf	2				
29	8.706-698.0	Cap, 0.812 Od x 1", Vinyl Black	1				
30	9.802-431.0	CFCI, 120V 20A, 36' 12-3 Cord	1				
31	8.920-274.0	Handle, Hotsy	1				
32	8.919-134.0	Coil Assy	1				
33	9.803-098.0	Holder	1				
34	8.706-731.0	Bushing, 3/4" Snap	1				
35	8.932-969.0	Label, Warning Service Cord	1				
36	9.804-517.0	Motor, 2Hp 1Ph 120V, 1725 Rpm 56C Odp	1				
37	8.706-216.0	Tee, 1/2" Fpt Steel	1				
38	8.705-975.0	Nipple, 1/2" Hex Steel	1				
39	8.706-243.0	Plug, 1/2" Square Head, Galv	1				
40	9.802-038.0	Nipple, 1/2" Jic x 1/2" Mpt Steel	1				

BURNER ASSEMBLY

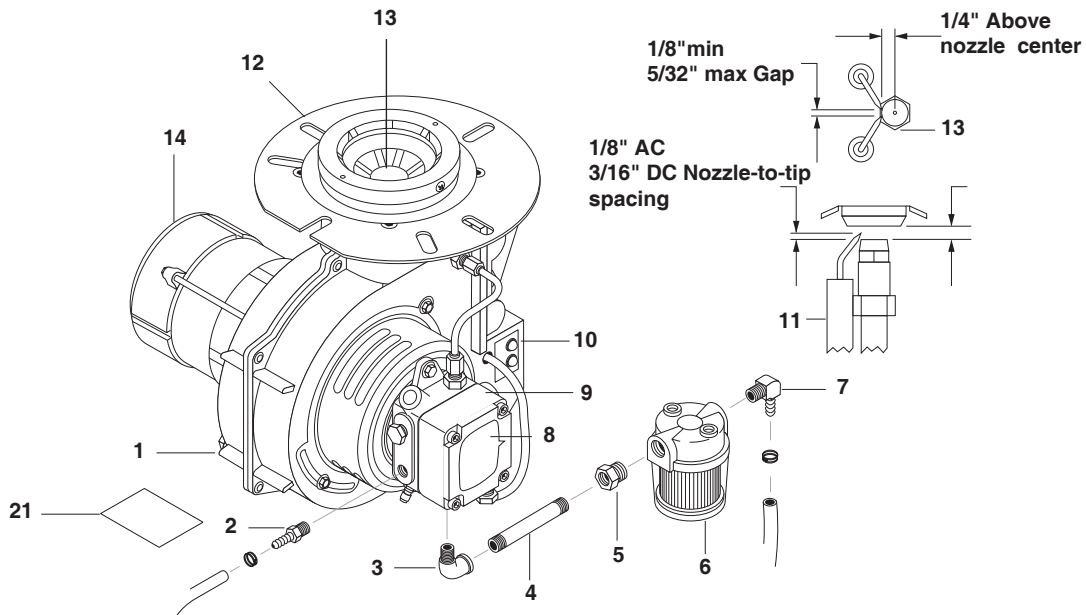

BURNER ASSEMBLY PARTS LIST

ITEM	PART NO.	DESCRIPTION	QTY	ITEM	PART NO.	DESCRIPTION	QTY
1	8.717-091.0	Burner, Beckett Afg, 120V 1.75 Noz	1	14	9.802-642.0	Burner Motor, 120V, 3450 Rpm 1/7 Hp	1
	8.918-908.0	Burner, 120V Crossfire			8.750-517.0	Motor, 115V Crossfire	1
2	8.706-941.0	Hose Barb, 1/4" Barb x 1/4" Mpt, Brass	1	15	8.717-711.0	▲ Filter Screen Replacement	1
3	8.706-161.0	Elbow, 1/4" Street, 90 Deg Galv	1	16	9.802-649.0	▲ Blower Wheel 4.25 x 2.5 Afg/Turb	1
4	9.803-043.0	Nipple, Pipe 1/4" x 2" Zinc Sch 80 Mpt	1		8.750-520.0	▲ Fan, Crossfire	1
5	8.706-297.0	Bushing, 3/8" x 1/4" Steel Yellow Chrom	1	17	8.717-853.0	▲ Coupling	1
6	8.709-153.0	Filter, Fuel Hotsy, 3/8" Female	1		8.751-543.0	▲ Coupling, Crossfire	1
7	8.706-965.0	Hose Barb, 1/4" Barb x 3/8" ML Pipe	1	18	9.802-646.0	▲ Valve Stem kit Cleancut Pump	1
8	9.802-645.0	Fuel Pump Cleancut 110V	1	19	9.802-666.0	▲ Screen, Fuel Pump	1
	8.700-759.0	Fuel Pump, 120V Crossfire	1	20	9.802-519.0	▲ Strain Relief, 1/2" Metal	1
9	8.700-779.0	Oil Solenoid Valve, 110V	1	21	9.801-264.0	Label, Hotsy Crossfire	1
10	9.802-647.0	Burner Ignitor, Afg/LoAmp Mount, 120V	1			▲ Not Shown	
	8.919-114.0	Igniter, 120V Crossfire	1				
11	9.802-670.0	Electrode kit	1				
	8.750-778.0	Electrode, Crossfire	1				
12	825676	Air Cone, 5-16	1				
	8.750-781.0	Air Cone F22 Crossfire	1				
13	8.717-346.0	Fuel Nozzle 1.75 x 90 A	1				

BURNER HOTSY CROSSFIRE EXPLODED VIEW

Replacement Parts

For best performance specify genuine KNA replacement parts

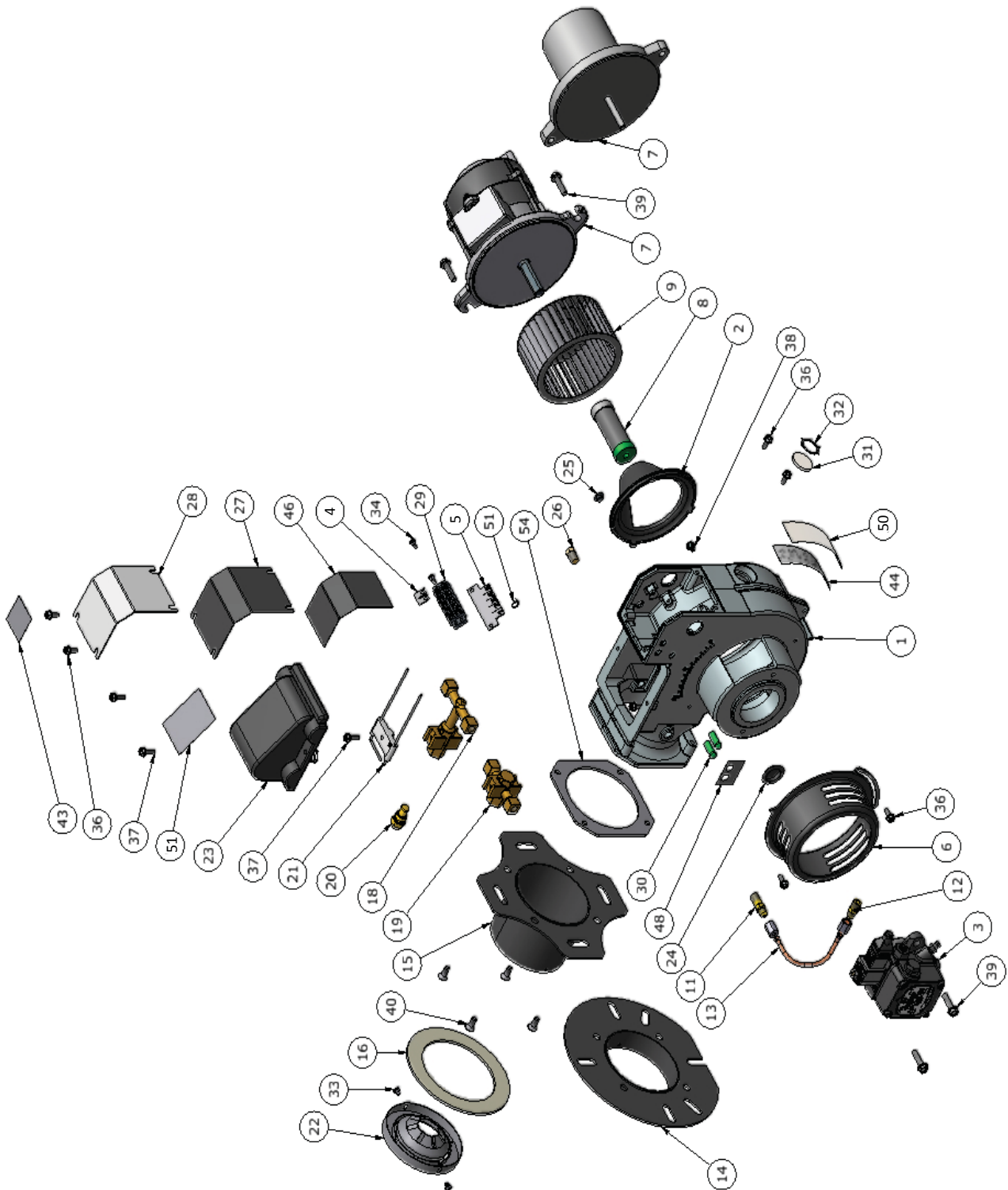

BURNER HOTSY CROSSFIRE PARTS LIST

Replacement Parts

For best performance specify genuine KNA replacement parts

Item #	Part #	Description	Qty
23	8.919-116.0	IGNITOR, BURNER 12VDC	1
24	8.751-165.0	PLUG, HOLE 0.875 PLASTIC	1
25	8.750-830.0	PLUG, HOLE 0.285 PLASTIC	1
26	8.751-134.0	PLUG, 1/8" NPT x HEX SHOULDER	1
27	8.918-454.0	GASKET, JUNCTION BOX	1
28	8.750-542.0	COVER, JUNCTION BOX	1
29	8.750-116.0	BLOCK, TERMINAL, 5 POLE	1
30	8.750-817.0	LIGHT, INDICATOR, GREEN 14V	2
30	8.750-818.0	LIGHT, INDICATOR, GREEN 28V	1
30	8.750-819.0	LIGHT, INDICATOR, GREEN 125V	1
30	8.750-820.0	LIGHT, INDICATOR, GREEN 250V	1
31	8.750-784.0	SITE GLASS	1
32	8.750-785.0	RING, PUSH ON INTERNAL, 1305-112	1
33	8.733-001.0	SCREW, 8 x 1/4" HI LOW THREAD CUT, PPH	2
34	8.718-762.0	SCREW, 8-32 X 1/2", M PH RDH PL	2
35	8.750-769.0	SCREW, 8/32 X 3/8" PH	1
36	8.718-810.0	SCREW, 10/32 x 1/2", WHIZ LOC FLANGE	6
37	8.750-770.0	SCREW, 10/32 x 5/8", WHIZ LOC FLANGE	3
38	8.750-816.0	SCREW, 10/32 X 1/4" GROUNDING	1
39	8.750-768.0	SCREW, 1/4-20 x 1", WHIZ LOC FLANGE	4
40	8.750-771.0	SCREW, 1/4-20 X 1/2", PHIL FHMS	4
42	—	LABEL, BRAND NAME	1
43	9.801-268.0	LABEL, DISCONNECT POWER SUPPLY	1
44	—	LABEL, SERIAL PLATE	1
46	9.807-339.0	LABEL, WIRING DIAGRAM, BURNER 120V-120V	1
46	9.807-340.0	LABEL, WIRING DIAGRAM, BURNER 230V-230V	4
46	9.807-341.0	LABEL, WIRING DIAGRAM, BURNER 230V-115V	1
46	9.807-342.0	LABEL, WIRING DIAGRAM, BURNER 120V-24V	1
46	9.807-343.0	LABEL, WIRING DIAGRAM, BURNER 230V-24V	1
46	9.807-344.0	LABEL, WIRING DIAGRAM, BURNER 12VDC	1
48	9.801-274.0	LABEL, BURNER LIGHTS	1
49	8.919-105.0	PLATE, TERMINAL BLOCK NUMBERS	1
50	8.716-451.0	TERMINAL, JUMPER SPADE	1
51	9.802-510.0	CABLE, TIE, 4" BLACK	2
52	9.807-348.0	LABEL, CLEAR MYLAR	1
53	9.807-345.0	LABEL, IGNITER 120V	1
53	9.807-346.0	LABEL, IGNITER 230V	1
53	9.807-347.0	LABEL, IGNITOR 12VDC	1

Item #	Part #	Description	Qty
1	8.919-050.0	BURNER HOUSING ASSEMBLY	1
2	8.751-160.0	AIR GUIDE	1
3	8.700-758.0	FUEL PUMP, SUNTEC A2VA-3106 12-24V SOL	1
3	8.700-759.0	FUEL PUMP, SUNTEC A2VA-3106 120V SOL	1
3	8.700-760.0	FUEL PUMP, SUNTEC A2VA-3106 230V SOL	1
3	8.753-000.0	FUEL PUMP, DANFOSS 071N1298	1
4	8.750-762.0	COIL, SOLENOID DANFOSS 230V	1
4	8.750-763.0	COIL, SOLENOID DANFOSS 120V	1
4	8.750-764.0	COIL, SOLENOID DANFOSS 12-24V	1
5	8.750-765.0	CABLE, SOLENOID COIL, DANFOSS	1
5a	8.750-763.0	MOUNTING KIT, FLANGE/HUB, DANFOSS	1
6	8.750-541.0	AIR BAND	1
7	8.750-517.0	MOTOR, 1/6 HP 120V 60Hz	1
7	8.750-518.0	MOTOR, 1/6 HP 230V 60Hz	1
7	8.751-074.0	MOTOR, 1/7 HP 12VDC AMETEK	1
8	8.750-543.0	COUPLING, FLEX, 1/2" x 5/16"	1
8	8.751-073.0	COUPLING, FLEX, 5/16" x 5/16"	1
9	8.750-520.0	FAN, 4.53" X 2.42", 1/2" BORE, F115-62S	1
9	8.751-072.0	FAN, 4.53" x 2.42" x .313 BORE, F115-625	1
11	8.750-547.0	CONNECTOR, 37 DEG FLARE X 1/8" NP LONG	1
12	8.750-545.0	CONNECTOR, 37 DEG FLARE X 1/8" NPT	1
13	8.749-000.0	FUEL LINE ASSEMBLY	1
14	8.918-864.0	FLANGE 1" TUBE ASSY, BURNER	1
15	8.918-866.0	FLANGE 3" TUBE ASSY, BURNER	1
16	8.750-539.0	GASKET, FLANGE	1
17	8.750-528.0	DISK, STATIC 2.00	1
17	8.918-868.0	DISK, STATIC 2.75	1
17	8.918-869.0	DISK, STATIC 2.50	1
17	8.918-870.0	DISK, STATIC 2.25	1
18	8.750-526.0	GUN, ELECTRODE / NOZZLE, 3"	1
19	8.750-525.0	GUN, ELECTRODE / NOZZLE, 1"	1
20	Varies	NOZZLE, FUEL	1
21	8.750-778.0	ELECTRODE, IGNITION	1
22	8.750-779.0	CONE, AIR F4	1
22	8.750-782.0	CONE, AIR F6	1
22	8.750-780.0	CONE, AIR F12	1
22	8.750-781.0	CONE, AIR F22	1
23	8.919-114.0	IGNITOR, BURNER 120V	1
23	8.919-115.0	IGNITOR, BURNER 230V	1

FUEL TANK ASSEMBLY

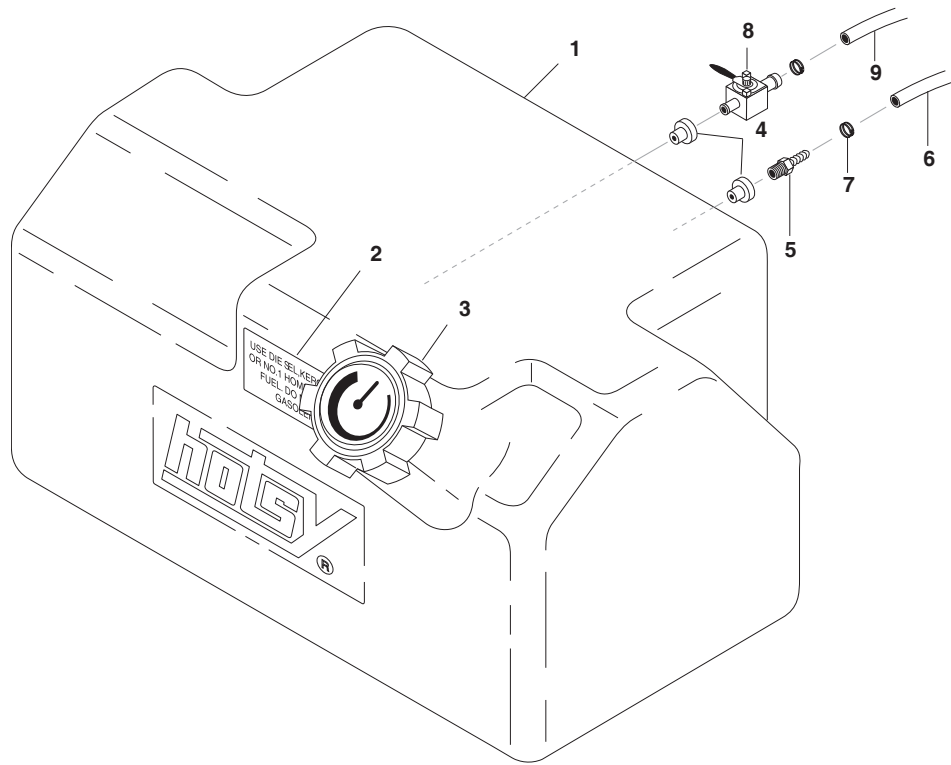

FUEL TANK ASSEMBLY PARTS LIST

ITEM	PART NO.	DESCRIPTION	QTY
1	8.706-614.0	Tank, Fuel, 8 Gal Hotsy	1
2	8.901-134.0	Label, Fuel Type	1
3	9.803-535.0	Cap With Fuel Display 14"	1
4	9.802-053.0	Bushing, Fuel Line, Rubber	2
5	9.802-141.0	Hose Barb, 1/4" Barb x 3/8", Barb, Dou	1
6	9.802-254.0	Hose, 1/4" Push-On, Ft	18"
7	6.390-126.0	Clamp, Hose, .46-.54 St	4
8	9.802-177.0	Valve, 1/4" Shut Off, 180 Deg	1
9	9.802-254.0	Hose 1/4" x 20" Push-On, Fuel Line	20"

CONTROL PANEL - EXPLODED

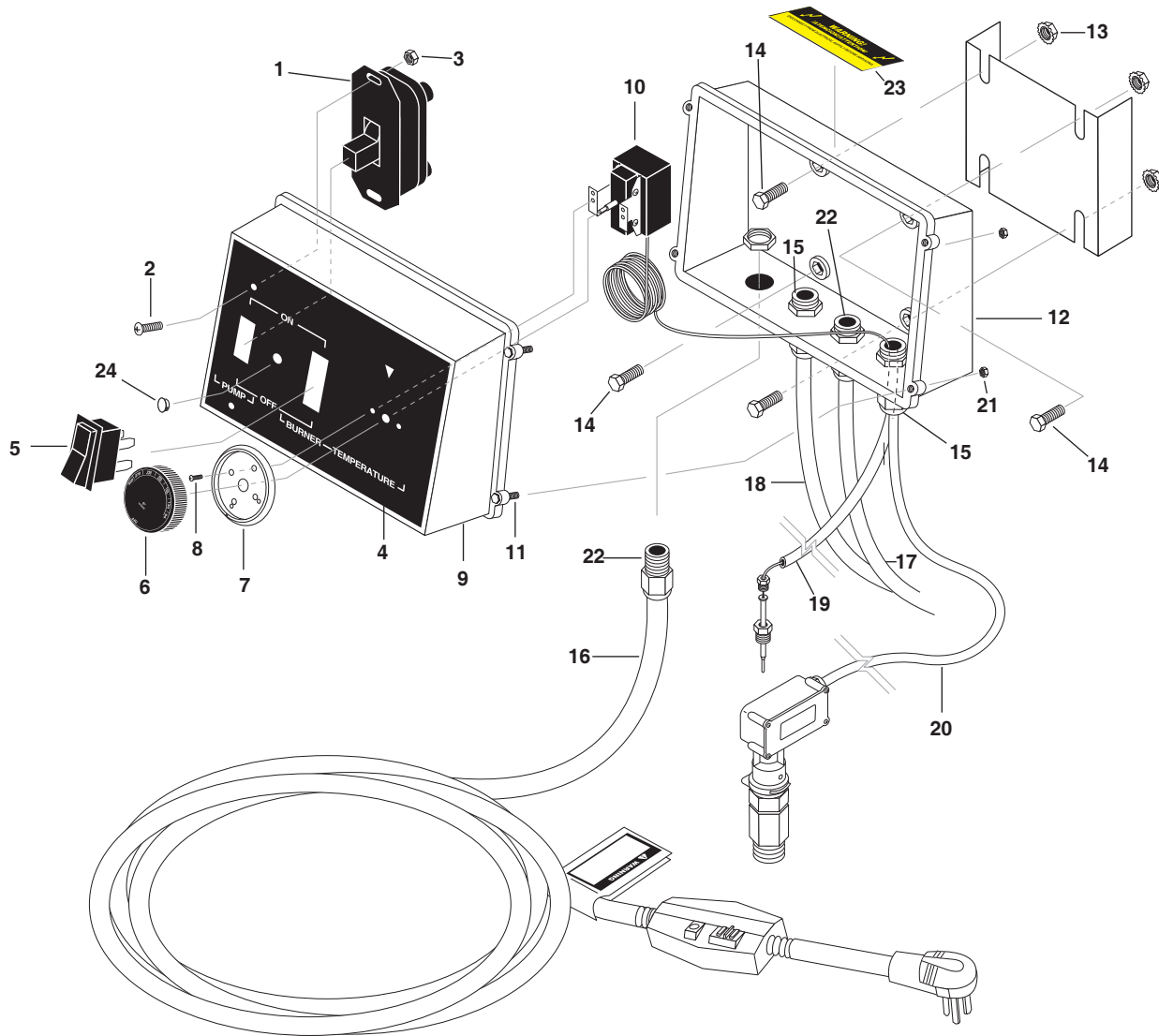

CONTROL PANEL PARTS LIST

ITEM	PART NO.	DESCRIPTION	QTY	ITEM	PART NO.	DESCRIPTION	QTY
1	8.716-053.0	Pump Switch	1	17	9.802-427.0	Cord 12/3 SOWA	36"
2	9.804-566.0	Screw #10 - 32 x 1/2"	2	18	9.802-424.0	Cord 16/4 SJO	53"
3	8.718-858.0	Hex Nut #10 - 32	2	19	9.804-072.0	Wire Cover	18"
4	8.901-142.0	Label, Control Box	1	20	8.716-125.0	Pressure Switch	1
5	8.716-054.0	Burner Switch	1	21	9.803-250.0	Nut	4
6	8.750-097.0	Thermostat Dial	1	22	8.752-969.0	Strain Relief, Lt, Str, 1/2 NPT	2
7	8.712-190.0	Thermostat mounting Plate	1	23	9.800-016.0	Label, Disconnect Power	1
8	8.718-779.0	Screw 4 mm x 6 mm	2	24	8.706-741.0	Plug, Plastic 7/16"	1
9	8.716-282.0	Control Box Front	1	REPLACEMENT PARTS			
10	8.750-095.0	Thermostat	1		8.717-667.0	O-Ring Kit	1
11	9.803-249.0	Screw, M4 x 10	4		8.717-256.0	Switch	1
12	9.802-480.0	Control Box Back	1				
13	9.802-775.0	Flange Nut 1/4" - 20	4				
14	9.802-700.0	Bolt 1/4" x 3/4"	4				
15	9.802-514.0	Strain Relief	2				
16	9.802-431.0	Power Cord W/ Gfci	1				

COIL OUTLET ASSEMBLY EXPLODED VIEW & PARTS LIST

ITEM	PART NO.	DESCRIPTION	QTY
1	9-149-003.0	Manifold Coil Outlet Discharge	1
2	8.706-241.0	Plug, 3/8" Sq Head Galv	1
3	9.196-012.0	Screw, 10-24 x 1/4" Hex Set	1
4	9.802-041.0	Elbow, 3/8" Street 45 Deg Steel	1
5	9.802-171.0	Coupler, 3/8" Plug, Male, Steel/Zinc	1
6	8.902-433.0	Valve, Safety Relief Vsa	1
7	8.711-785.0	Hose, 3/8" Push On, Per Ft	33.5"
8	9.800-021.0	Label, Hot Water Outlet	1

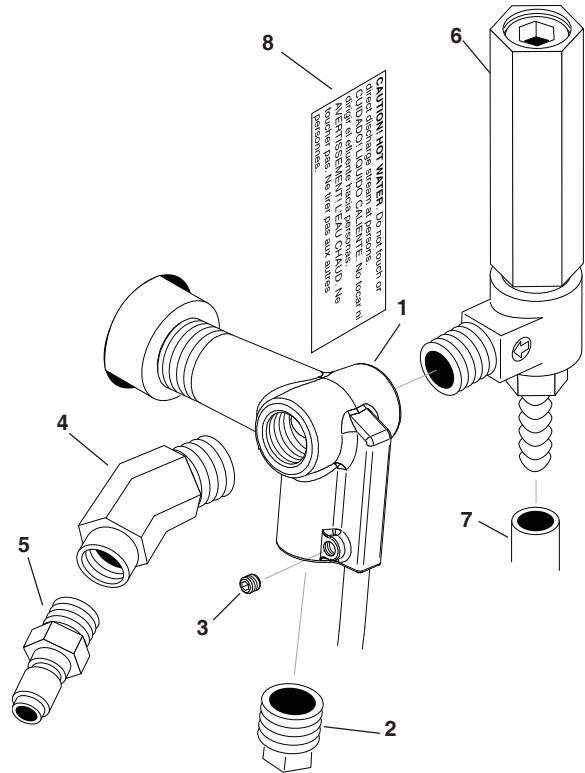

HOSE, GUN & WAND ASSEMBLY AND PARTS LIST

ITEM	PART NO.	DESCRIPTION	QTY
1	8.712-406.0	Nozzle, Variable Fan, 1/4" F#6	1
2	8.725-389.0	Wand, Single, 36", Insulated W/ Side Grip	1
3	9.802-164.0	Coupler, 1/4" Socket, Female, Brass	1
4	8.707-139.0	Coupler, 1/4" Plug, Male, Steel/Zinc	1
5	8.751-235.0	Gun, Hotsy, H1050, 5000 PSI, 10.4 Gpm	1
6	8.739-011.0	Hose, 3/8" x 50', 1W, Ts, Hotsy 1 So x Sw	1

REPLACEMENT PARTS

8.717-661.0	Grip, Handle Assy Hotsy	1
8.706-670.0	Grip, Wand Side Handle	1
8.751-119.0	Kit, Gun Repair	1

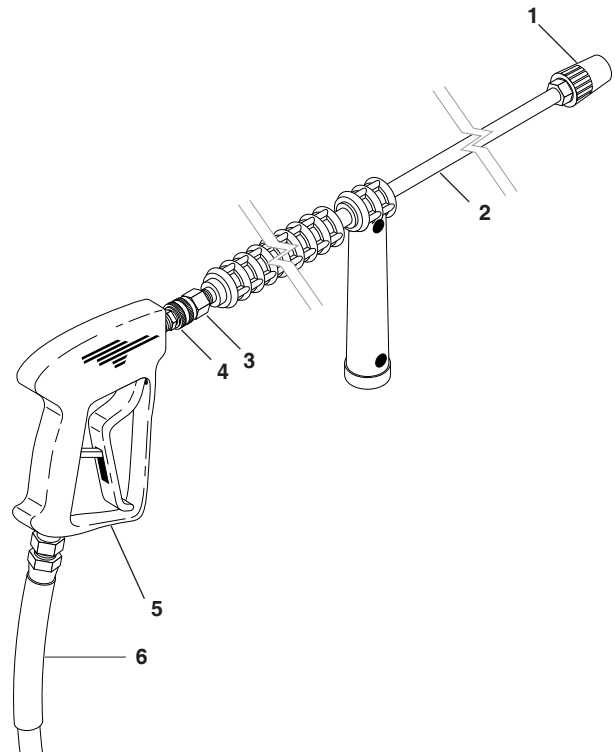

PUMP ASSEMBLY

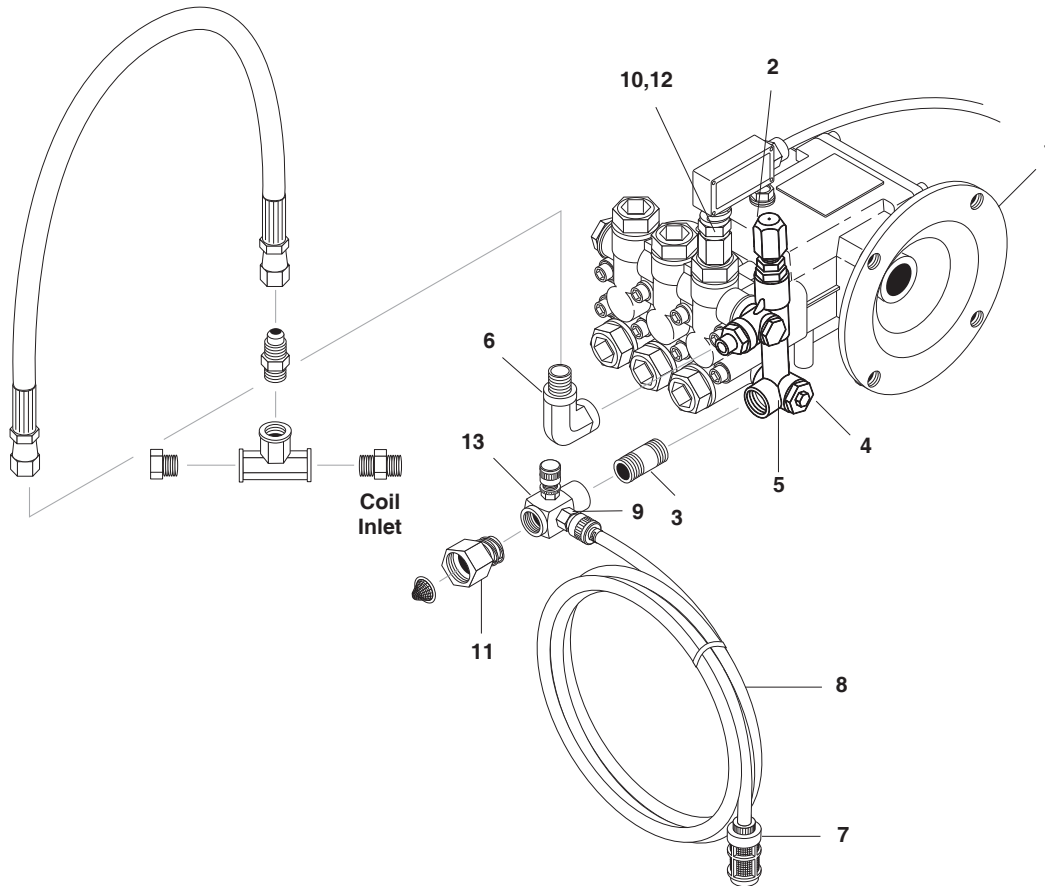

PUMP ASSEMBLY PARTS LIST

ITEM	PART NO.	DESCRIPTION	QTY	REPLACEMENT PARTS
1	8.715-241.0	Pump	1	8.717-672.0 O-Ring Repair Kit
2	8.715-491.0	Unloader, HM ST/MT Unset (921460)	1	8.717-673.0 Discharge Repair Kit
3	8.706-788.0	Nipple, 3/8" X 1-1/2" L Brass"	1	8.717-674.0 Stem Repair Kit
4	9.803-919.0	Bolt Unloader Valve	2	8.717-667.0 O-Ring Kit
5	9.802-893.0	Washer Unloader Valve	4	8.717-256.0 Switch
6	9.802-042.0	Elbow, 1/2 Jic X 3/8 Fem, 90°	1	
7	8.707-056.0	Detergent Screen	1	
8	9.802-252.0	Vinyl Tubing 1/4"	4 ft.	
9	6.390-126.0	Hose Clamp	1	
10	8.707-264.0	Manifold Plug 3/8"	1	
11	9.802-147.0	Garden Hose Connector	1	
12	8.719-008.0	Copper Washer	1	
13	9.803-275.0	Detergent Injector	1	
14	9.802-179.0	Valve, Anti-Siphon	1	

PUMP - EXPLODED VIEW

8.904-911.0 HHC205L.1
 8.715-253.0 HHC215R.1
 8.715-241.0 HHC235R.1
 8.904-920.0 HHC240.1
 8.715-254.0 HHC280.1

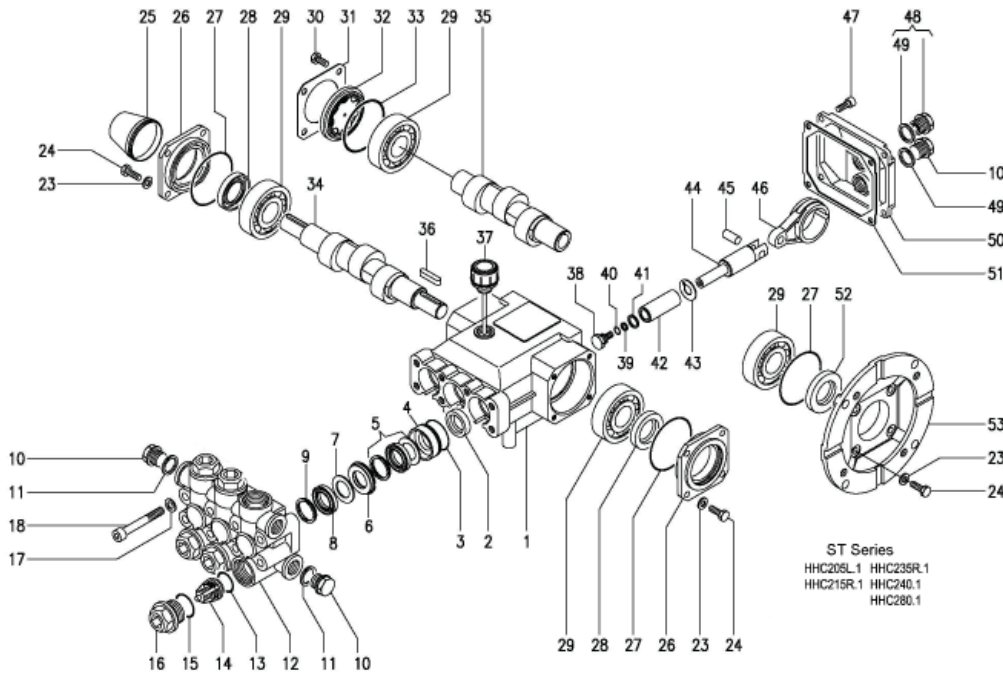

TORQUE SPECS	
Item #	Ft.-lbs
16	65
18	18
24	7.6
38	7
48	13

ST Series
 HHC205L.1 HHC235R.1
 HHC215R.1 HHC240.1
 HHC280.1

PUMP - EXPLODED VIEW PARTS LIST

ITEM	PART NO.	DESCRIPTION	QTY	ITEM	PART NO.	DESCRIPTION	QTY
1	8.717-121.0	Crankcase	1	18	8.717-526.0	Manifold Stud Bolt	8
2*	See Kit Below	Plunger Oil Seal	3	23	9.803-210.0	Washer (205L.1,215R.1, 235R.1) (240.1, 280.1)	4
3*	See Kit Below	O-Ring Ø 1.78 x 31.47	3	24	8.717-539.0	Hex Screw (205L.1,215R.1, 235R.1) (240.1, 280.1)	8
4*	See Kit Below	Pressure Ring 18mm	3	25	8.717-148.0	Shaft Protector(240.1, 280.1)	1
	See Kit Below	Pressure Ring 20mm	3	26	8.717-195.0	Open Flange (240.1, 280.1)	2
5*	See Kit Below	U-Seal, dia 18mm	3	27	8.717-225.0	O-Ring, Ø 2.62 x 61.6 205L.1, 215R.1, 235R.1) (240.1, 280.1)	4
	See Kit Below	U-Seal, dia 20mm	3	28	8.717-020.0	Shaft Oil Seal (240.1, 280.1)	2
6*	See Kit Below	Intermediate Ring 18mm	3	29	9.802-955.0	Ball Bearing	2
	See Kit Below	Intermediate Ring 20mm	3	30	8.717-540.0	Hexagonal Screw (205L.1,215R.1, 235R.1)	4
7*	See Kit Below	Back Ring, 18mm	3	31	9.803-953.0	Bearing Cover (205L.1, 215R.1, 235R.1)	1
	See Kit Below	Back Ring, 20mm	3	32	8.717-259.0	Sight Glass (205L.1,215R.1, 235R.1)	1
8*	See Kit Below	U-Seal, 18mm	3	33	9.804-581.0	O-Ring, Ø 3.53 x 55.56 (205L.1, 215R.1, 235R.1)	1
	See Kit Below	U-Seal, 20mm	3	34	8.730-821.0	Crankshaft (2 PTO) 240.1, 280.1)	1
9*	See Kit Below	Support Ring, 18mm	3				
	See Kit Below	Support Ring, 20mm	3				
10	9.802-925.0	Brass Plug G3/8	3				
11	9.803-198.0	Copper Washer 3/8	2				
12	9.802-931.0	Manifold Housing	1				
13*	See Kit Below	O-Ring Ø2.62 x 18.72	6				
14*	See Kit Below	Valve Assembly	6				
15*	See Kit Below	O-Ring Ø2.62 x 23.47	6				
16	9.802-924.0	Valve Plug	6				
17	9.802-884.0	Washer	8				

PUMP - EXPLODED VIEW PARTS LIST

ITEM	PART NO.	DESCRIPTION	QTY
35	8.717-056.0	Crankshaft Hollow (205L.1, 215R.1)	1
	8.717-057.0	Crankshaft Hollow (235R.1)	1
36	8.717-151.0	Crankshaft Key 240.1, 280.1)	1
37	9.803-957.0	Oil Dip Stick	1
38*	See Kit Below	Plunger Bolt	3
39*	See Kit Below	O-Ring Ø 1.78 x 7.66	3
40*	See Kit Below	Teflon Ring	3
41*	See Kit Below	Copper Spacer	3
42*	See Kit Below	Plunger 18mm Plunger 20mm	3 3
43*	See Kit Below	Copper Spacer	3
44	8.717-040.0	Plunger Rod	3
45	9.803-965.0	Connecting Rod Pin	3
46	8.717-111.0	Connecting Rod	3
47	9.802-939.0	Cover Screw	4
48	9.803-201.0	Sight Glass (240.1, 280.1)	1
49	9.803-197.0	Gasket, G3/8	1
50	8.717-136.0	Crankcase Cover (240.1)	1
	8.717-140.0	Crankcase Cover (205L.1, 215R.1, 235R.1, 280.1)	1
51	8.717-215.0	Cover Gasket	1
52	9.803-140.0	Shaft Oil Seal (205L.1, 215R.1, 235R.1)	1
53	8.717-197.0	Motor Flange (205L.1, 215R.1, 235R.1)	1

REPAIR KIT NUMBER	8.725-360.0	8.725-362.0	8.725-415.0	8.725-407.0	8.717-632.0	8.717-617.0	8.717-584.0	8.717-585.0
KIT DESCRIPTION	Plunger Seal 18mm 205L.1 240.1 280.1	Plunger Seal 20mm 215R.1 235R.1	Complete Seal Packing 18mm 205L.1 240.1 280.1	Complete Seal Packing 20mm 215R.1 235R.1	Plunger 18mm 205L.1 240.1 280.1	Plunger 20mm 215R.1 235R.1	Complete Valve	Plunger Oil Seals
ITEM NUMBERS INCLUDED	3, 5, 7, 8, 9	3, 5, 7, 8, 9	3, 4, 5, 6, 7, 8, 9	3, 4, 5, 6, 7, 8, 9	38, 39, 40, 41, 42, 43	38, 39, 40, 41, 42, 43	13, 14, 15	3
NO. OF CYLINDERS KIT WILL SERVICE	3	3	1	1	1	1	6	3

VBA UNLOADER EXPLODED VIEW

8.715-491.0
5-3303
#921460

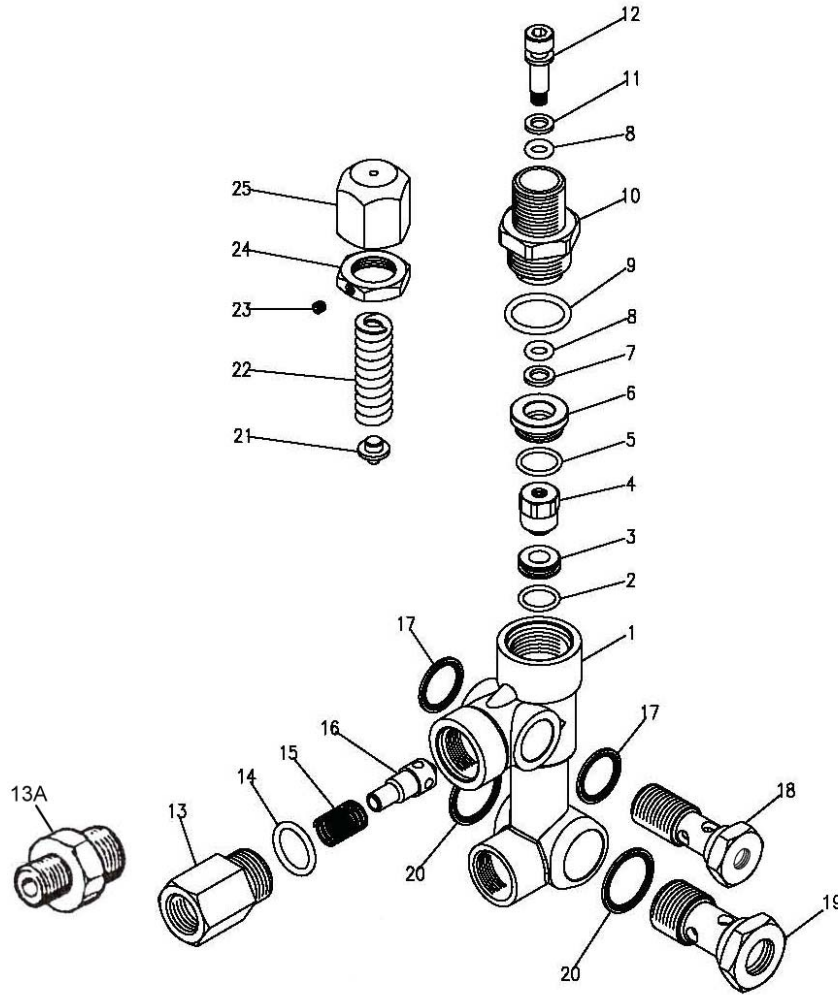

VBA UNLOADER EXPLODED VIEW PARTS LIST

ITEM	PART NO.	DESCRIPTION	KIT	QTY	ITEM	PART NO.	DESCRIPTION	KIT	QTY
1		Body Valve (KG)		1	16		Poppet	B	1
		Body Valve (KS)		1	17	9.802-893.0	Seal Washer 3/8		2
2		O-Ring	A,C	1	18	9.803-915.0	Banjo Bolt 3/8" w 1/8" Pilot		1
3		Seat	C	1		9.803-919.0	Banjo Bolt 3/8" Solid Cap		1
4		Ball, Sub-Assy	C	1	19	9.803-920.0	Banjo Bolt 1/2" w 1/4" Pilot		1
5		O-Ring	A	1		8.750-105.0	Banjo Bolt 1/2" Solid Cap		
6	9.803-907.0	Guide Bushing		1		9.803-919.0	Banjo Bolt 3/8" Solid Cap		
7		Teflon Ring		1	20	9.803-921.0	Seal Washer 1/2		2
8		O-Ring	A	1	21		Plate	C	1
9		O-Ring	A	2	22		Spring	C	1
10	9.803-911.0	Connector		1	23	8.933-021.0	Set Screw		1
11		Teflon Ring	A	1	24	9.803-925.0	Nut		1
12	70-120207	Stem	C	1	25	9.803-926.0	Brass Handle		1
13	9.803-941.0	Connector Female		1	Kit A	8.717-672.0	O-Ring Repair Kit		
13A	9.702-892.0	Connector Male		1	Kit B	8.717-673.0	Outlet Kit		
14		O-Ring	A,B	1	Kit C	8.717-674.0	Stem Repair Kit		
15		Spring	B	1					

WIRING DIAGRAM

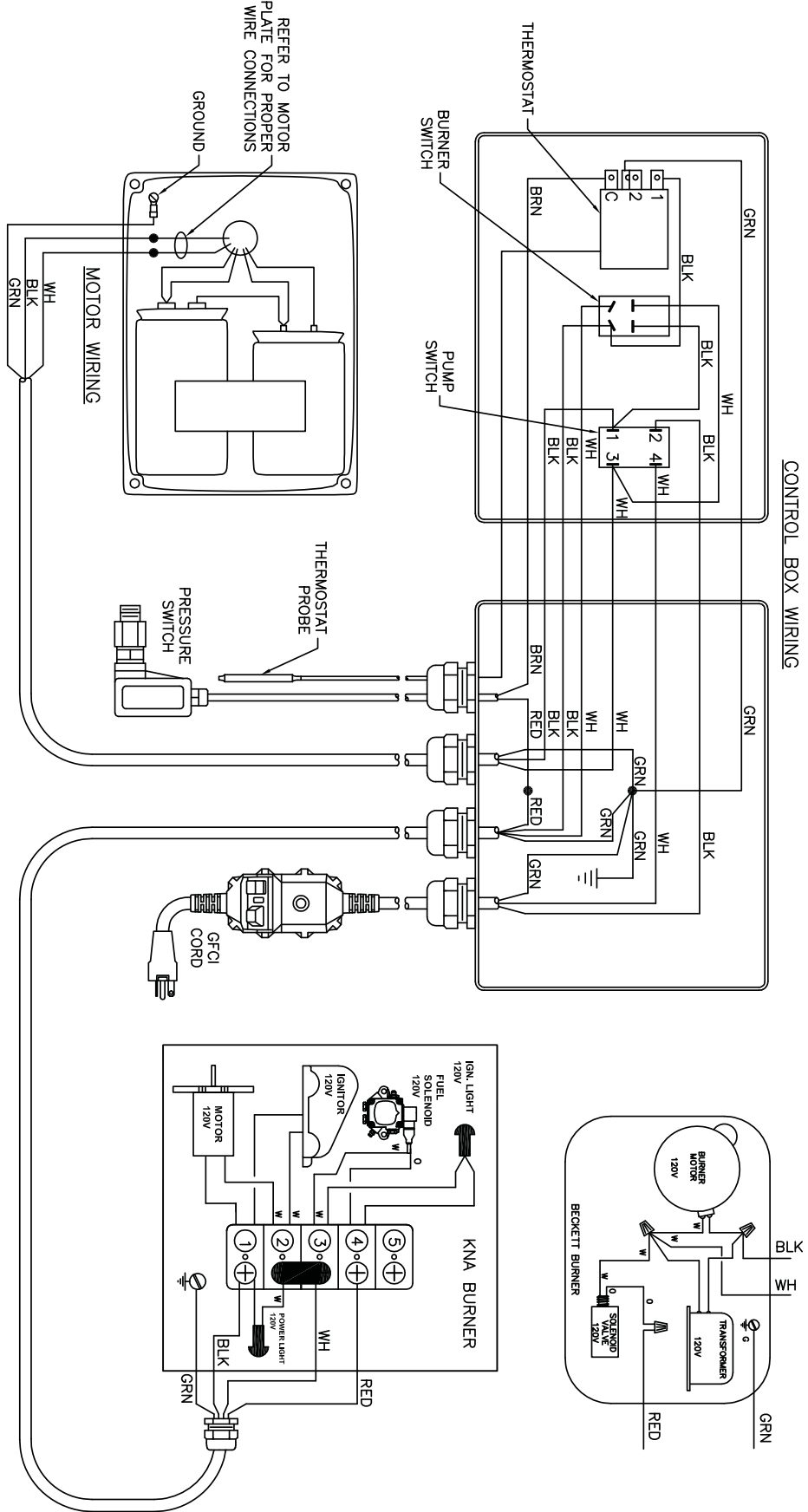

If you need **SERVICE** on your pressure washer, contact your local Hotsy dealer or visit www.Hotsy.com. Smart phone users scan the code below to link directly to the Service Request page.



To **REGISTER** your pressure washer, please visit our Warranty Registration page at www.hotsy.com/WarrantyRegistration.aspx or scan the code below with your smart phone.

