

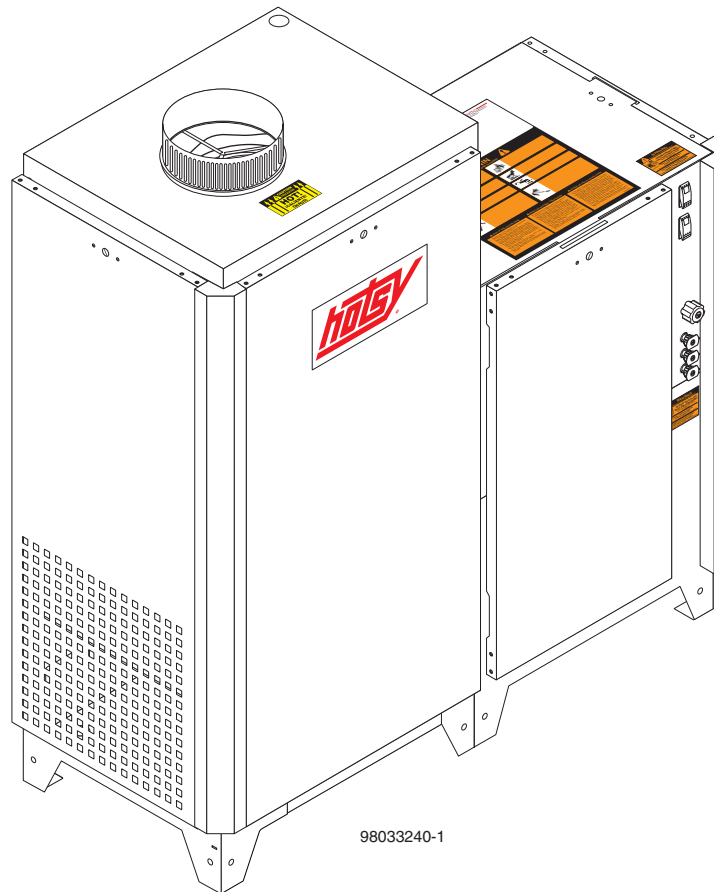

900/1400 GAS-FIRED SERIES

DEALER MANUAL



FOR TECHNICAL ASSISTANCE OR THE HOTSY DEALER NEAREST YOU, CONSULT OUR WEB PAGE AT
WWW.HOTSY.COM

SYMBOLS

Identification of Operational Label Symbols



Burner Switch



Pump Switch



Hour Meter



Steam Combination



Detergent

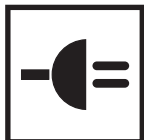

Voltage

When the light is on, it means power supply is on



Pilot Light

When the light is on, it means there is power to the pilot control.
If there is no light, see troubleshooting guide.



Motor Overload

When the light is on, it means the overload is tripped.
Reset overload.

1.109-691.0 921N SPECIFICATIONS

- Pump Volume At Pump Head: 4.0 GPM/228 GPH
- Pump Pressure At Pump Head: 2300 PSI
- Burner Type: Natural Gas Fired, 364,835 BTU/Hr.
- Motor Hp: 6.2
- Machine Voltage: 208VAC/60Hz/1Ph
- Total Machine Amperage: 28 Amps
- Machine Weight: 560 Lbs.
- Shipping Weight: 620 Lbs.
- Exhaust Stack Size: 8"
- Machine Dimensions: Length=47.5", Width=21", Height=51"

1.109-692.0 926N SPECIFICATIONS

- Pump Volume At Pump Head: 4.0 GPM/228 GPH
- Pump Pressure At Pump Head: 2000 PSI
- Burner Type: Natural Gas Fired, 364,835 BTU/Hr.
- Motor Hp: 5
- Machine Voltage: 575VAC/60Hz/3Ph
- Total Machine Amperage: 7 Amps
- Machine Weight: 555 Lbs.
- Shipping Weight: 610 Lbs.
- Exhaust Stack Size: 8"
- Machine Dimensions: Length=47.5", Width=21", Height=51"

1.109-695.0 943P SPECIFICATIONS

- Pump Volume At Pump Head: 4.0 GPM/234 GPH
- Pump Pressure At Pump Head: 2000 PSI
- Burner Type: LP Gas Fired, 360,997 BTU/Hr.
- Motor Hp: 5.0
- Machine Voltage: 230VAC/60Hz/1Ph
- Total Machine Amperage: 25 Amps
- Machine Weight: 550 Lbs.
- Shipping Weight: 610 Lbs.
- Exhaust Stack Size: 8"
- Machine Dimensions: Length=47.5", Width=21", Height=51"

1.109-696.0 943N SPECIFICATIONS

- Pump Volume At Pump Head: 4.0 GPM/234 GPH
- Pump Pressure At Pump Head: 2000 PSI
- Burner Type: Natural Gas Fired, 364,835 BTU/Hr.
- Motor Hp: 5.0
- Machine Voltage: 230VAC/60Hz/1Ph
- Total Machine Amperage: 25 Amps
- Machine Weight: 550 Lbs.
- Shipping Weight: 610 Lbs.
- Exhaust Stack Size: 8"
- Machine Dimensions: Length=47.5", Width=21", Height=51"

1.109-697.0 944P SPECIFICATIONS

- Pump Volume At Pump Head: 4.0 GPM/234 GPH
- Pump Pressure At Pump Head: 2000 PSI
- Burner Type: LP Gas Fired, 360,997 BTU/Hr.
- Motor Hp: 5.0
- Machine Voltage: 230VAC/60Hz/3Ph
- Total Machine Amperage: 16 Amps
- Machine Weight: 545 Lbs.
- Shipping Weight: 605 Lbs.
- Exhaust Stack Size: 8"
- Machine Dimensions: Length=47.5", Width=21", Height=51"

1.109-693.0 942P SPECIFICATIONS

- Pump Volume At Pump Head: 4.0 GPM/234 GPH
- Pump Pressure At Pump Head: 2000 PSI
- Burner Type: LP Gas Fired, 360,997 BTU/Hr.
- Motor Hp: 5.0
- Machine Voltage: 208VAC/60Hz/3Ph
- Total Machine Amperage: 18 Amps
- Machine Weight: 545 Lbs.
- Shipping Weight: 605 Lbs.
- Exhaust Stack Size: 8"
- Machine Dimensions: Length=47.5", Width=21", Height=51"

1.109-694.0 942N SPECIFICATIONS

- Pump Volume At Pump Head: 4.0 GPM/234 GPH
- Pump Pressure At Pump Head: 2000 PSI
- Burner Type: Natural Gas Fired, 364,835 BTU/Hr.
- Motor Hp: 5.0
- Machine Voltage: 208VAC/60Hz/3Ph
- Total Machine Amperage: 18 Amps
- Machine Weight: 545 Lbs.
- Shipping Weight: 605 Lbs.
- Exhaust Stack Size: 8"
- Machine Dimensions: Length=47.5", Width=21", Height=51"

1.109-698.0 944N SPECIFICATIONS

- Pump Volume At Pump Head: 4.0 GPM/234 GPH
- Pump Pressure At Pump Head: 2000 PSI
- Burner Type: Natural Gas Fired, 364,835 BTU/Hr.
- Motor Hp: 5.0
- Machine Voltage: 230VAC/60Hz/3Ph
- Total Machine Amperage: 16 Amps
- Machine Weight: 545 Lbs.
- Shipping Weight: 605 Lbs.
- Exhaust Stack Size: 8"
- Machine Dimensions: Length=47.5", Width=21", Height=51"

1.109-699.0 945P SPECIFICATIONS

- Pump Volume At Pump Head: 4.0 GPM/234 GPH
- Pump Pressure At Pump Head: 2000 PSI
- Burner Type: LP Gas Fired, 360,997 BTU/Hr.
- Motor Hp: 5.0
- Machine Voltage: 460VAC/60Hz/3Ph
- Total Machine Amperage: 8 Amps
- Machine Weight: 545 Lbs.
- Shipping Weight: 605 Lbs.
- Exhaust Stack Size: 8"
- Machine Dimensions: Length=47.5", Width=21", Height=51"

1.109-700.0 945N SPECIFICATIONS

- Pump Volume At Pump Head: 4.0 GPM/234 GPH
- Pump Pressure At Pump Head: 2000 PSI
- Burner Type: Natural Gas Fired, 364,835 BTU/Hr.
- Motor Hp: 5.0
- Machine Voltage: 460VAC/60Hz/3Ph
- Total Machine Amperage: 8 Amps
- Machine Weight: 545 Lbs.
- Shipping Weight: 605 Lbs.
- Exhaust Stack Size: 8"
- Machine Dimensions: Length=47.5", Width=21", Height=51"

1.109-704.0 1453P SPECIFICATIONS

- Pump Volume At Pump Head: 4.0 GPM/234 GPH
- Pump Pressure At Pump Head: 3000 PSI
- Burner Type: LP Gas Fired, 360,997 BTU/Hr.
- Motor Hp: 7.5
- Machine Voltage: 230VAC/60Hz/1Ph
- Total Machine Amperage: 34 Amps
- Machine Weight: 610 Lbs.
- Shipping Weight: 670 Lbs.
- Exhaust Stack Size: 8"
- Machine Dimensions: Length=47.5", Width=21", Height=51"

1.109-705.0 1453N SPECIFICATIONS

- Pump Volume At Pump Head: 4.0 GPM/234 GPH
- Pump Pressure At Pump Head: 3000 PSI
- Burner Type: Natural Gas Fired, 364,835 BTU/Hr.
- Motor Hp: 7.5
- Machine Voltage: 230VAC/60Hz/1Ph
- Total Machine Amperage: 34 Amps
- Machine Weight: 610 Lbs.
- Shipping Weight: 670 Lbs.
- Exhaust Stack Size: 8"
- Machine Dimensions: Length=47.5", Width=21", Height=51"

1.109-706.0 1454P SPECIFICATIONS

- Pump Volume At Pump Head: 4.0 GPM/234 GPH
- Pump Pressure At Pump Head: 3000 PSI
- Burner Type: LP Gas Fired, 360,997 BTU/Hr.
- Motor Hp: 7.5
- Machine Voltage: 230VAC/60Hz/3Ph
- Total Machine Amperage: 25 Amps
- Machine Weight: 605 Lbs.
- Shipping Weight: 665 Lbs.
- Exhaust Stack Size: 8"
- Machine Dimensions: Length=47.5", Width=21", Height=51"

1.109-702.0 1452P SPECIFICATIONS

- Pump Volume At Pump Head: 4.0 GPM/234 GPH
- Pump Pressure At Pump Head: 3000 PSI
- Burner Type: LP Gas Fired, 360,997 BTU/Hr.
- Motor Hp: 7.5
- Machine Voltage: 208VAC/60Hz/3Ph
- Total Machine Amperage: 24 Amps
- Machine Weight: 605 Lbs.
- Shipping Weight: 665 Lbs.
- Exhaust Stack Size: 8"
- Machine Dimensions: Length=47.5", Width=21", Height=51"

1.109-707.0 1454N SPECIFICATIONS

- Pump Volume At Pump Head: 4.0 GPM/234 GPH
- Pump Pressure At Pump Head: 3000 PSI
- Burner Type: Natural Gas Fired, 364,835 BTU/Hr.
- Motor Hp: 7.5
- Machine Voltage: 230VAC/60Hz/3Ph
- Total Machine Amperage: 24 Amps
- Machine Weight: 605 Lbs.
- Shipping Weight: 665 Lbs.
- Exhaust Stack Size: 8"
- Machine Dimensions: Length=47.5", Width=21", Height=51"

1.109-703.0 1452N SPECIFICATIONS

- Pump Volume At Pump Head: 4.0 GPM/234 GPH
- Pump Pressure At Pump Head: 3000 PSI
- Burner Type: Natural Gas Fired, 364,835 BTU/Hr.
- Motor Hp: 7.5
- Machine Voltage: 208VAC/60Hz/3Ph
- Total Machine Amperage: 24 Amps
- Machine Weight: 605 Lbs.
- Shipping Weight: 655 Lbs.
- Exhaust Stack Size: 8"
- Machine Dimensions: Length=47.5", Width=21", Height=51"

1.109-708.0 1455P SPECIFICATIONS

- Pump Volume At Pump Head: 4.0 GPM/234 GPH
- Pump Pressure At Pump Head: 3000 PSI
- Burner Type: LP Gas Fired, 360,997 BTU/Hr.
- Motor Hp: 7.5
- Machine Voltage: 460VAC/60Hz/3Ph
- Total Machine Amperage: 12 Amps
- Machine Weight: 605 Lbs.
- Shipping Weight: 665 Lbs.
- Exhaust Stack Size: 8"
- Machine Dimensions: Length=47.5", Width=21", Height=51"

1.109-709.0 1455N SPECIFICATIONS

- Pump Volume At Pump Head: 4.0 GPM/234 GPH
- Pump Pressure At Pump Head: 3000 PSI
- Burner Type: Natural Gas Fired, 364,835 BTU/Hr.
- Motor Hp: 7.5
- Machine Voltage: 460VAC/60Hz/3Ph
- Total Machine Amperage: 12 Amps
- Machine Weight: 605 Lbs.
- Shipping Weight: 665 Lbs.
- Exhaust Stack Size: 8"
- Machine Dimensions: Length=47.5", Width=21", Height=51"

1.109-701.0 1451N SPECIFICATIONS

- Pump Volume At Pump Head: 4.0 GPM/234 GPH
- Pump Pressure At Pump Head: 3000 PSI
- Burner Type: Natural Gas Fired, 364,835 BTU/Hr.
- Motor Hp: 8.2
- Machine Voltage: 208VAC/60Hz/1Ph
- Total Machine Amperage: 36.5 Amps
- Machine Weight: 615 Lbs.
- Shipping Weight: 675 Lbs.
- Exhaust Stack Size: 8"
- Machine Dimensions: Length=47.5", Width=21", Height=51"

1.109-710.0 1456N SPECIFICATIONS

- Pump Volume At Pump Head: 4.0 GPM/234 GPH
- Pump Pressure At Pump Head: 3000 PSI
- Burner Type: Natural Gas Fired, 364,835 BTU/Hr.
- Motor Hp: 8.2
- Machine Voltage: 575VAC/60Hz/3Ph
- Total Machine Amperage: 10 Amps
- Machine Weight: 615 Lbs.
- Shipping Weight: 675 Lbs.
- Exhaust Stack Size: 8"
- Machine Dimensions: Length=47.5", Width=21", Height=51"

1.109-713.0 1473N SPECIFICATIONS

- Pump Volume At Pump Head: 5 GPM/300 GPH
- Pump Pressure At Pump Head: 3000 PSI
- Burner Type: Natural Gas Fired, 390,025 BTU/Hr.
- Motor Hp: 10 HP
- Machine Voltage: 230VAC/60Hz/1Ph
- Total Machine Amperage: 42 Amps
- Machine Weight: 617 Lbs.
- Shipping Weight: 677 Lbs.
- Exhaust Stack Size: 8"
- Machine Dimensions: Length=47.5", Width=21", Height=51"

1.109-714.0 1474N SPECIFICATIONS

- Pump Volume At Pump Head: 5 GPM/300 GPH
- Pump Pressure At Pump Head: 3000 PSI
- Burner Type: LP Gas Fired, 390,025 BTU/Hr.
- Motor Hp: 10 HP
- Machine Voltage: 230VAC/60Hz/3Ph
- Total Machine Amperage: 29 Amps
- Machine Weight: 620 Lbs.
- Shipping Weight: 680 Lbs.
- Exhaust Stack Size: 8"
- Machine Dimensions: Length=47.5", Width=21", Height=51"

1.109-948.0 921P SPECIFICATIONS

- Pump Volume At Pump Head: 4.0 GPM/234 GPH
- Pump Pressure At Pump Head: 2300 PSI
- Burner Type: LP Gas Fired, 360,997 BTU/Hr.
- Motor Hp: 6.2
- Machine Voltage: 208VAC/60Hz/1Ph
- Total Machine Amperage: 28 Amps
- Machine Weight: 560 Lbs.
- Shipping Weight: 620 Lbs.
- Exhaust Stack Size: 8"
- Machine Dimensions: Length=47.5", Width=21", Height=51"

1.109-949.0 926P SPECIFICATIONS

- Pump Volume At Pump Head: 4.0 GPM/234 GPH
- Pump Pressure At Pump Head: 2000 PSI
- Burner Type: Natural Gas Fired, 360,997 BTU/Hr.
- Motor Hp: 5.0
- Machine Voltage: 575VAC/60Hz/3Ph
- Total Machine Amperage: 7 Amps
- Machine Weight: 555 Lbs.
- Shipping Weight: 610 Lbs.
- Exhaust Stack Size: 8"
- Machine Dimensions: Length=47.5", Width=21", Height=51"

1.109-711.0 1473P SPECIFICATIONS

- Pump Volume At Pump Head: 5 GPM/300 GPH
- Pump Pressure At Pump Head: 3000 PSI
- Burner Type: LP Gas Fired, 378,617 BTU/Hr.
- Motor Hp: 10 HP
- Machine Voltage: 230VAC/60Hz/1Ph
- Total Machine Amperage: 42 Amps
- Machine Weight: 617 Lbs.
- Shipping Weight: 677 Lbs.
- Exhaust Stack Size: 8"
- Machine Dimensions: Length=47.5", Width=21", Height=51"

1.109-712.0 1474P SPECIFICATIONS

- Pump Volume At Pump Head: 5 GPM/300 GPH
- Pump Pressure At Pump Head: 3000 PSI
- Burner Type: LP Gas Fired, 378,617 BTU/Hr.
- Motor Hp: 10 HP
- Machine Voltage: 230VAC/60Hz/3Ph
- Total Machine Amperage: 29 Amps
- Machine Weight: 620 Lbs.
- Shipping Weight: 680 Lbs.
- Exhaust Stack Size: 8"
- Machine Dimensions: Length=47.5", Width=21", Height=51"

1.109-950.0 1451P SPECIFICATIONS

- Pump Volume At Pump Head: 4.0 GPM/234 GPH
- Pump Pressure At Pump Head: 3000 PSI
- Burner Type: LP Gas Fired, 360,997 BTU/Hr.
- Motor Hp: 8.2 HP
- Machine Voltage: 208VAC/60Hz/1Ph
- Total Machine Amperage: 36.5 Amps
- Machine Weight: 615 Lbs.
- Shipping Weight: 675 Lbs.
- Exhaust Stack Size: 8"
- Machine Dimensions: Length=47.5", Width=21", Height=51"

1.109-951.0 1456P SPECIFICATIONS

- Pump Volume At Pump Head: 4.0 GPM/234 GPH
- Pump Pressure At Pump Head: 3000 PSI
- Burner Type: LP Gas Fired, 360,997 BTU/Hr.
- Motor Hp: 8.2 HP
- Machine Voltage: 575VAC/60Hz/1Ph
- Total Machine Amperage: 10 Amps
- Machine Weight: 615 Lbs.
- Shipping Weight: 675 Lbs.
- Exhaust Stack Size: 8"
- Machine Dimensions: Length=47.5", Width=21", Height=51"

1.109-952.0 1475P SPECIFICATIONS

- Pump Volume At Pump Head: 5.0 GPM/300 GPH
- Pump Pressure At Pump Head: 3000 PSI
- Burner Type: LP Gas Fired, 360,997 BTU/Hr.
- Motor Hp: 10 HP
- Machine Voltage: 208VAC/60Hz/3Ph
- Total Machine Amperage: *** Amps
- Machine Weight: *** Lbs.
- Shipping Weight: *** Lbs.
- Exhaust Stack Size: 8"
- Machine Dimensions: Length=47.5", Width=21", Height=51"

1.109-953.0 1475N SPECIFICATIONS

- Pump Volume At Pump Head: 5.0 GPM/300 GPH
- Pump Pressure At Pump Head: 3000 PSI
- Burner Type: LP Gas Fired, 378,617 BTU/Hr.
- Motor Hp: 10 HP
- Machine Voltage: 208VAC/60Hz/3Ph
- Total Machine Amperage: *** Amps
- Machine Weight: *** Lbs.
- Shipping Weight: *** Lbs.
- Exhaust Stack Size: 8"
- Machine Dimensions: Length=47.5", Width=21", Height=51"

CONTENTS

Introduction & Important Safety Information	7-9
Component Identification	10
Assembly Instructions	11
Installation Instructions	12-15
Operation Instructions	16-17
Shutdown Instructions	18
Storage	18
Maintenance	19
Smart Relay Instructions	20-22
Optional Water Inlet Solenoid	23
Frame Bolt-up Assembly Exploded View and Parts List	24
Burner Box Assembly Exploded View and Parts List	25
Coil Assembly Exploded View and Parts List	26
Pump and Unloader Assembly Exploded View and Parts List	27
Float Tank Assembly Exploded View and Parts List	28
Tensioner Assembly Exploded View and Parts List	29
Electrical Box Assembly Exploded View and Parts List	30-31
Component Cube Assembly Exploded View and Parts List	32-33
Power Side Assembly Exploded View and Parts List	34-35
Panel and Doors Exploded View and Parts List	36-37
Hose and Gun Assembly Exploded View and Parts List	38
Troubleshooting	39-43
Specifications	44-45
HM.3 Series Pump Exploded View and Parts List	46-47
VB9 Unloader Exploded View and Parts List	48
Wire Diagram	49
Warranty	

Model Number _____

Serial Number _____

Date of Purchase _____

The model and serial numbers will be found on a decal attached to the pressure washer. You should record both serial number and date of purchase and keep in a safe place for future reference.

INTRODUCTION & IMPORTANT SAFETY INFORMATION

Thank you for purchasing this Pressure Washer. We reserve the right to make changes at any time without incurring any obligation.

WARNING: If the information in this manual is not followed exactly, a fire or explosion may result causing property damage, personal injury or death.

Do not store or use gasoline or other flammable vapors and liquids in the vicinity of this or any other appliance.

WHAT TO DO IF YOU SMELL GAS

- Do not try to light any appliance.
- Do not touch any electrical switch; do not use any phone in your building.
- Immediately call your gas supplier from a neighbor's phone. Follow the gas supplier's instructions.
- If you cannot reach your gas supplier, call the fire department.

Installation and service must be performed by a qualified installer, service agency or the gas supplier.

Owner/User Responsibility:

The owner and/or user must have an understanding of the manufacturer's operating instructions and warnings before using this pressure washer. Warning information should be emphasized and understood. If the operator is not fluent in English, the manufacturer's instructions and warnings shall be read to and discussed with the operator in the operator's native language by the purchaser/owner, making sure that the operator comprehends its contents.

Owner and/or user must study and maintain for future reference the manufacturers' instructions.

The operator must know how to stop the machine quickly and understand the operation of all controls. Never permit anyone to operate the engine without proper instructions.

SAVE THESE INSTRUCTIONS

This manual should be considered a permanent part of the machine and should remain with it if machine is resold.

When ordering parts, please specify model and serial number. Use only identical replacement parts.

This machine is to be used only by trained operators.

IMPORTANT SAFETY INFORMATION

WARNING: If you do not follow these instructions exactly, a fire or explosion may result, causing property damage, personal injury or loss of life.

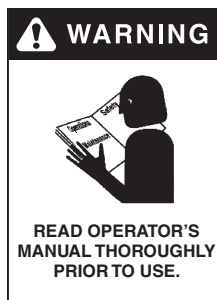

WARNING: To reduce the risk of injury, read operating instructions carefully before using.

1. Read the owner's manual thoroughly. Failure to follow instructions and warnings could cause malfunction of the machine and result in death, serious bodily injury and/or property damage.
2. Know how to stop the machine and bleed pressure quickly. Be thoroughly familiar with the controls.
3. Stay alert — watch what you are doing.
4. Use only your hand to push in or turn the gas control knob. Never use a tool. If the knob will not push in or turn by hand, don't try to repair it; call a qualified service technician.
5. All installations must comply with local codes. Contact your electrician, plumber, utility company or the selling distributor for specific details.

DANGER: Improper connection of the equipment-grounding conductor can result in a risk of electrocution. Check with a qualified electrician or service personnel if you are in doubt as to whether the outlet is properly grounded.



DANGER: Keep wand, hose, and water spray away from electric wiring or fatal electric shock may result.

6. To protect the operator from electrical shock, the machine must be electrically grounded. It is the responsibility of the owner to connect this

machine to a grounded receptacle of proper voltage and amperage ratings. Do not spray water on or near electrical components. Do not touch machine with wet hands or while standing in water. Always disconnect power before servicing.

IMPORTANT SAFETY INFORMATION

! WARNING



RISK OF EXPLOSION:
IF GAS SMELL PRESENT
TURN OFF SUPPLY

WARNING: Flammable liquids can create fumes which can ignite, causing property damage or severe injury.

WARNING: Risk of explosion — Operate only where open flame or torch is permitted. Do not spray flammable liquids.

! WARNING



RISK OF FIRE.
DO NOT ADD FUEL
WHEN OPERATING
MACHINE.

WARNING: Risk of fire — Do not change LP tanks when the product is operating or still hot.

WARNING: Use vapor fuel only.

7. Gas appliances shall be installed only in locations where combustible dusts and flammable gases or vapors are not present. Do not store or use gasoline near this machine.

WARNING: In the event of a pilot outage, wait at least five minutes to clear out any gas before relighting.

8. Keep operating area clear of all persons.

! WARNING



USE PROTECTIVE
EYE WEAR
AND CLOTHING
WHEN OPERATING
THIS EQUIPMENT.

WARNING: High pressure spray can cause paint chips or other particles to become airborne and fly at high speeds. To avoid personal injury, eye, hand and foot safety devices must be worn.

9. Eye, hand, and foot protection must be worn when using this equipment.

! WARNING



EAR PROTECTION
MUST BE WORN

WARNING: This machine exceeds 85 db appropriate ear protection must be worn.

! WARNING



RISK OF INJURY.
HOT SURFACES
CAN CAUSE BURNS

WARNING: Risk of injury. Hot surfaces can cause burns. Use only designated gripping areas of spray gun and wand. Do not place hands or feet on non-insulated areas of the pressure washer.

10. To reduce risk of injury, close supervision is necessary when a machine is used near children. Do not allow children to operate pressure washer. **This machine must be attended during operation.**

! WARNING



TRIGGER GUN KICKS
BACK - HOLD WITH
BOTH HANDS

WARNING: Grip cleaning wand securely with both hands before starting. Failure to do this could result in injury from a whipping wand.

11. Never make adjustments on machine while in operation.

12. Move spray gun trigger lever into locked position before

inserting the high pressure nozzle into the quick coupler. Be certain all quick coupler fittings are secured before using pressure washer.

! WARNING



RISK OF INJECTION
OR SEVERE INJURY
TO PERSONS. KEEP
CLEAR OF NOZZLE.

WARNING: High pressure developed by these machines will cause personal injury or equipment damage. Keep clear of nozzle. Use caution when operating. Do not direct discharge stream at people, or severe injury or death will result.

! WARNING



PROTECT FROM
FREEZING

WARNING: Protect machine from freezing.

13. To keep machine in best operating conditions, it is important you protect machine from freezing. Failure to protect machine from freezing could cause malfunction of the machine and result in death, serious bodily injury, and/or property damage. Follow storage instructions specified in this manual.

! WARNING



RISK OF
ASPHYXIATION. USE
THIS PRODUCT ONLY
IN A WELL
VENTILATED AREA.

WARNING: Risk of asphyxiation. Use this product only in a well ventilated area.

14. Avoid installing machines in small areas or near exhaust fans. Adequate oxygen is needed for combustion or dangerous carbon monoxide will result.

15. Manufacturer will not be liable for any changes made to our standard machines or any components not purchased from us.

16. The best insurance against an accident is precaution and knowledge of the machine.

IMPORTANT SAFETY INFORMATION



WARNING: *Be extremely careful when using a ladder, scaffolding or any other relatively unstable location. The cleaning area should have adequate slopes and drainage to reduce the possibility of a fall due to slippery surfaces.*

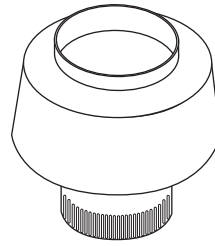

Example of Down Draft Diverter for Gas Fired Machines

17. Do not overreach or stand on unstable support. Keep good footing and balance at all times.
18. Do not operate this machine when fatigued or under the influence of alcohol, prescription medications, or drugs.
19. Follow the maintenance instructions specified in the manual.

WARNING: *Use vapor fuel only.*

20. The LP models are designed to run on vapor propane fuel. Do not use liquid fuel. Have a qualified serviceman install and service your equipment.
21. Never expose a spark or flame where there may be unburned gas present.
22. Install this machine about 2 feet from wall to provide adequate ventilation and servicing space. This equipment incorporates parts such as snap switches or similar parts that tend to produce arcs or sparks. Therefore, when located in a garage, it should be in a room or enclosure provided for the purpose or should be installed 18" (457mm) or more above the floor.

WARNING: *To reduce the risk of electric shock, disconnect all electrical connections and shut-off gas valve before servicing.*

23. Install this machine on non combustible flooring.
24. Do not allow acids, caustic or abrasive fluids to pass through the pump.
25. Never run pump dry or leave spray gun closed longer than 3 minutes.

WARNING: *If connection is made to potable water supply, a back flow device must be provided.*

26. Exhaust gases should not be vented into a wall, a ceiling or a concealed space of a building. A draft diverter must be installed to prevent down draft and to allow cooling of exhaust temperatures. Down draft diverters shall be installed in the vents and located at a distance from the pressure washer stack to achieve maximum draft of 36" minimum. Exhaust gases that exceed 470°F (243°C) are not suitable for connection to Type B gas vents.



Follow the maintenance instructions specified in the manual.

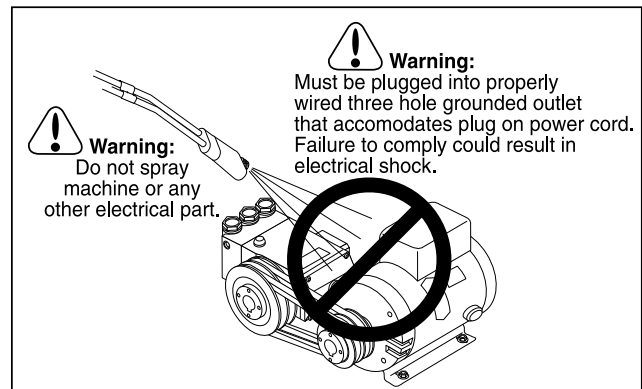

ASSEMBLY INSTRUCTIONS

Unpacking

Unpack carefully. Wear safety glasses or goggles while unpacking, assembling or operating pressure washer. If there are missing components or hidden damage immediately contact distributor or carrier concerning discrepancies.

1. Cut strapping band from pressure washer and pallet.
2. Remove pressure washer from pallet.

Parts Included

- Pressure Washer
- Pressure Hose
- Wand
- Parts Box Containing:
 - Pressure Nozzles (3 ea.)
 - Trigger Gun
- Operating Instructions and Parts Manual

Tools Required

- 10" Adjustable Crescent Wrenches (2 ea.)
- Blade Screwdriver

Pressure Hose, Wand and Wand Holder

1. Use teflon tape on plumbing connections to prevent leakage.
2. Install pressure hose on machine as shown.
3. Assemble wand components as shown. Connect pressure hose to trigger gun.

NOTE: The nozzle is not to be installed at this time.

4. Make sure that all plumbing connections are tight.

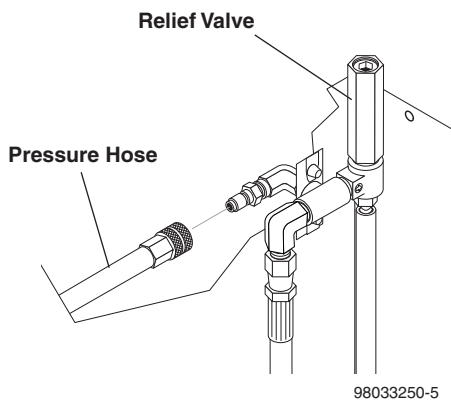
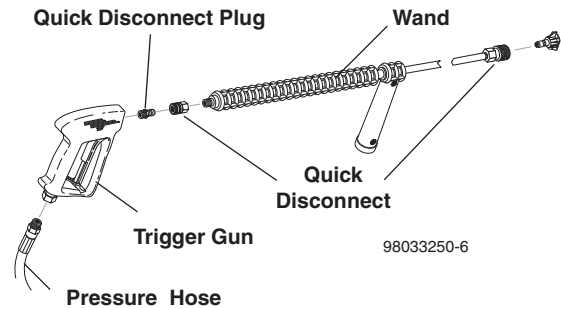

INSTALLATION INSTRUCTIONS

Getting Started:

IMPORTANT: Proper installation will assure satisfactory performance, longer service life and lower maintenance costs.

Location:

The location should protect machine from damaging environmental conditions, such as wind, rain and freezing.

1. The machine should be run on a level surface where it is not readily influenced by outside sources such as strong winds, freezing temperatures, rain, etc. The machine should be located considering accessibility for the replacing of components and the refilling of detergents, adjustments and maintenance. Normal precautions should be taken by the operator of the machine to prevent excess moisture from reaching the machine.
2. It is recommended that a partition be made between the wash area and machine to prevent direct spray from the spray gun from coming in contact with the machine. Excess moisture reaching the power unit or electrical controls will reduce the machine's life and may cause electrical shorts.
3. During installation of the machine, beware of poorly ventilated locations or areas where exhaust fans may cause an insufficient supply of oxygen. Sufficient combustion can only be obtained when there is a sufficient supply of oxygen available for the amount of fuel being burned. If it is necessary to install a machine in a poorly ventilated area, outside fresh air may have to be piped to the burner and a fan installed to bring the air into the area.
4. Do not locate near any combustible material. Keep all flammable material at least 20 feet away.
Allow enough space for servicing the machine.
Local code will require certain distances from floor and walls. (Two feet away should be adequate).

WARNING: Avoid small areas or near exhaust fans.

Gas Codes:

Confer with local gas company and with proper municipal officials regarding any specific code or regulations governing the installation. The installation must conform to local codes (U.S., ANSI Z223.1/NFPA54 National Fuel Gas Code; Canada, CAN 1-B149 Installation Code).

Electrical:

The machine, when installed, must be electrically grounded in accordance to local codes. Check for proper power supply using a volt meter; check the serial plate for the correct requirements.

Gas Piping:

This machine shall be rigidly connected to the gas piping outlet and equipped with external manual shut-off valves adjacent to such machine. All gas piping shall be approved and installed in accordance with the Uniform Mechanical Code.

Install a gas union in the gas line adjacent to and upstream from the control manifold and downstream from the manual main shut-off valve. A 1/8" NPT plugged tapping accessible for test gauge connection shall be installed immediately upstream of the gas supply connection for the purpose of determining the gas supply pressure to the burner, and to prevent damage to gas valve.

If a manual gas shut off valve is not in the gas supply line within six feet of the machine and in an accessible location, one shall be installed.

Figure 1: Union Location

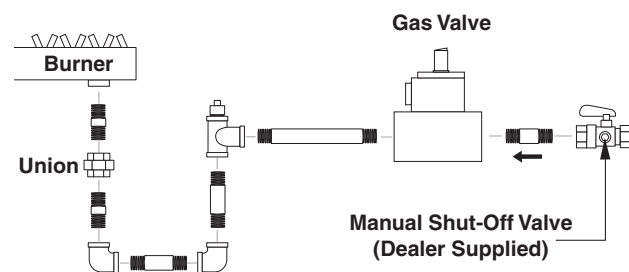

98033250-10

Union Connection

The following pipe sizes are just recommendations. Always consult a local plumber and venting contractor for local codes and regulations during installation.

Pipe Sizing Chart for Natural Gas

The following chart is based on gas pressure in the range 0-0.5 psi, specific gravity of 0.6 and pressure loss of 0.5" W.C. Numbers are for straight schedule 40 pipe; fittings further reduce capacity. For example, in 1" size, an elbow is equivalent to about 2.6 feet of pipe and a tee is equivalent to about 5.2 feet of pipe.

INSTALLATION INSTRUCTIONS

Length of Pipe (ft.)	Iron Pipe Size				
	3/4"	1"	1-1/4"	1-1/2"	2"
10	360	680	1400	2100	3950
20	250	465	950	1460	2750
30	200	375	770	1180	2200
40	170	320	660	990	1900
50	151	285	580	900	1680
60	138	260	530	810	1520
70	125	240	490	750	1400
80	118	220	460	690	1300
90	110	205	430	650	1220
100	103	195	400	620	1150
150	84	160	325	500	950
200	72	135	280	430	800

Maximum capacity of pipe in cubic feet/hr of natural gas (Multiply values by 1000 to get nominal BTU/hr capacity.)

LP-Gas (Liquid petroleum gas or propane)

LP-gas is gas compressed into liquid form for easy transportation and storage. It is also known as propane or bottle gas. (Propane tanks are not supplied with this equipment.)

LP-gas is flammable, is always contained under pressure and the liquid can freeze skin. Therefore, in the interest of safety, it is important to understand the basic facts about LP-gas and LP-gas containers.

Federal DOT (Department of Transportation) regulations require periodic inspections and re-qualifications of cylinders. DO NOT USE damaged or rusted containers.

DO NOT store LP-gas containers indoors or in enclosed areas. Do not expose LP-gas container to heat. Always store with service valve closed and plugged as required.

CAUTION: Use LP-gas containers in proper position.

Most LP-gas pressure washer heaters are designed to operate on LP-gas vapor only. Therefore, all LP-gas containers designed for vapor service must be transported, installed and used in the proper position. Do not transport, install or use a vertical cylinder in a horizontal or upside down position. Proper care must be taken to position a horizontal container in the correct position for vapor withdrawal. Liquid LP-gas could enter the system designed for vapor only, possibly creating a hazardous condition.

Always use a POL plug installed on a POL valve or a dust cap on an ACME/Type 1 valve when transporting or storing disconnected containers (full or empty).

Check for leaks after connecting. Apply approved leak detector solution to connection, turn off all burners and pilots and open service valve. Leaks will be detected by the growth of bubbles. If bubbles grow, tighten or repair the connection as needed. Repeat leak test until problem is corrected.

Check all tank and the line connections periodically to be sure they are tight. When testing for leaks, use approved leak detector solution — not matches.

Improved Regulation: The second stage regulator receives a relatively uniform pressure from the first stage regulator. This helps the second stage regulator to maintain appliance pressure at a nearly constant 11" W.C.

Filling the LP-Gas Container

Only qualified persons should fill your LP-gas containers.

CAUTION: Overfilling is hazardous!

DO NOT allow your LP-gas container to be overfilled. Stop filling when liquid appears at the fixed level gauge. Bleed off excess propane in a safe area. Most LP-gas containers are equipped with a fixed liquid level gauge which contacts the liquid level at 80% of container capacity, allowing 20% for expansion. LP-gas containers not equipped with a fixed liquid level gauge can only be filled by weight.

In cold climates, in order to keep vaporization of LP-gas at the highest level, keep the fuel levels above 50%.

Combustion and Ventilation Air

Properly sized vents are vital for the safe and efficient operation of a pressure washer installed in a confined space. When combustion and ventilation air are supplied from inside the building, each opening must have an area of one square inch for every 1,000 BTUH input. When combustion air is supplied from the outside, each opening must have an area of one square inch for every 2,000 BTUH for horizontal ducts and one square inch for every 4,000 BTUH for vertical ducts (refer to NFPA 54). See Figure 2.

The purpose of venting a gas pressure washer is to completely remove all products of combustion and to vent gasses to the outside air without condensation in the vent or spillage at the draft hood (except in cases of downdraft or poor stack conditions). To assure correct venting, use a strong, gas-tight insulated pipe with a cross section equal to that of the flue collar or draft hood outlet and of sufficient vertical height.

During vent installation, avoid sharp turns, long horizontal runs and improper pitches. Maintain proper support of vent connectors and joints, observe clearances from all combustibles and top the vent outlet with an approved cap.

INSTALLATION INSTRUCTIONS

Type "B", due to its temperature rating, can only be used with natural draft pressure washers. A "B" vent is designed for exhaust temperatures not to exceed 470°F (245°C).

All venting installations must conform to local codes. In the absence of local codes, refer to "National Fuel Gas Code" NFPA 54 and be constructed of materials approved by the Uniform Building Code.

Vents penetrating ceilings or walls should be double-wall approved appliance vents and should be one to two inches from combustibles. Vents passing through enclosed spaces and vents exposed to the weather should also be the double-wall type. Sometimes vents have to be built of such great length that they come apart at their joints under their own weight. These should be screwed together at the joints with sheet metal screws, usually three per joint. If the inspector indicates that the vent is too close to combustibles, it may be necessary to chisel away some of the combustible or route the vent pipe around the combustible. The cross-sectional area of any flue shall not be less than the cross-sectional area of the flue vent connection outlet of machine.

Figure 2: Ventilation

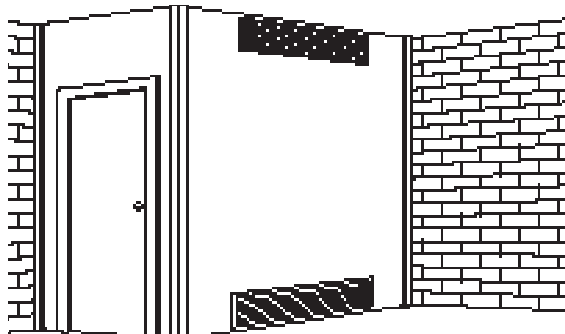

Illustration showing air openings necessary to supply air for combustion when installed in an enclosed room.

Water Source:

The water source for the machine should be supplied by a 5/8" I.D. garden hose with a city water pressure of not less than 30 PSI. If the water supply is inadequate, or if the garden hose is kinked, the machine will run very rough and the burner will not fire.

Water Connection:

Connect the high pressure hose by pulling the coupler collar back and then inserting it onto the discharge nipple. Secure it by pushing the collar forward.

Attach the wand into the spray gun using teflon tape on the pipe threads to avoid leaks.

Inspection and Testing Gas Piping:

The building structure should not be weakened by installing the gas piping. The piping should not be supported by other piping, but should be firmly supported with gas hooks, straps, bands or hangers. Butt or lap welded pipe should not be run through or in an air duct or clothes chute.

Before turning gas under pressure into piping, all openings from which gas can escape should be closed. Immediately after turning on gas, the system should be checked for leaks. This can be done by watching the 1/2 cubic foot test dial for 5 minutes for any movement or by soaping each pipe connection and watching for bubbles. If a leak is found, make the necessary repairs and repeat the above test.

Defective pipes or fittings should be replaced and not repaired. Never use a flame or fire in any form to locate gas leaks — use a soap solution.

After the piping and meter have been checked completely, purge the system of air. **DO NOT** bleed the air inside an enclosed room.

During pressure testing of the system at test pressures in excess of 1/2 PSIG, the pressure washer and its individual shut-off valve must be disconnected from gas supply piping system or damage to the gas valve will occur.

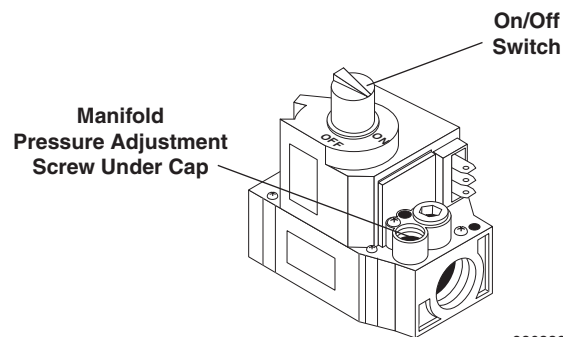

Outlet View

98033250-7

Gas Pressure:

The ideal incoming gas pressure is 11 w.c.i. (water column inches). Minimum is 9 w.c.i., maximum is 14 w.c.i. or 1/2 PSIG. The correct operating manifold pressure for natural gas is 2.8 w.c.i. The operating manifold pressure for propane gas is 7.5 w.c.i. By adjusting the gas valve pressure regulator between 3 and 4 w.c.i. a side range can be achieved for natural gas.

If the desired input rating cannot be obtained within the above manifold pressure adjusting range, then the next size larger or smaller burner orifice should be used.

INSTALLATION INSTRUCTIONS

The gas pressure coming out of the regulator and going to the burner ring has been factory set for elevations of 0 to 2000 ft. Altitudes greater than 2000 ft will require adjustments to the gas manifold pressures. Consult your local service dealer/distributor for high altitude adjustments. In Canada, certification for installation at altitudes over 4500 feet above sea level is the jurisdiction of local authorities. You should not readjust the burner ring gas pressure. If you replace your gas valve, you will need to adjust the new valve. Refer to your machine's **specification plate** for the correct pressure setting. Follow the installation and adjustment instructions provided with your replacement valve.

NOTE: Air for combustion and ventilation along with exhaust flue sizing must conform to methods outlined in current American Standard (ANSI-Z223.1) National Fuel Gas Code or National Standard of Canada CSA-149.1 and CSA-149.2 "Installation Code for Gas Burning Appliances".

OPERATION INSTRUCTIONS

Before Starting

1. Read all manuals provided with this pressure washer. Become familiar with location and function of all operating and safety controls.

WARNING: Check hoses, fittings, wand, trigger gun and fuel connections daily for signs of wear, cracks and looseness, and replace as required.

2. Connect water supply hose to the standard garden hose connector. The water faucet and supply hose must be capable of providing 6.0 GPM.
3. This machine was factory built for natural gas/propane. See instructions under **Fuel Supply**.
4. Check pump oil level.
5. If detergents are to be used, only use detergents intended for pressure washers. Follow instructions on the detergent container.

IMPORTANT: Before installing pressure nozzle on initial start-up, turn on the water supply, start the pump by pressing the pump ON switch, and hold the wand trigger open until water appears at the end of the wand. Allow water to run from the end of the wand until clear to prevent the nozzle from clogging.

6. Install the pressure nozzle on end of wand, refer to illustration below.

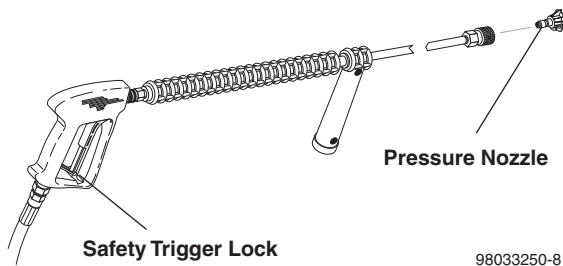

IMPORTANT: The trigger gun provided with this pressure washer is equipped with a manual trigger lock to prevent accidental operation of the trigger gun, refer to figure above. The safety trigger lock should be used whenever the trigger gun is not in use.

IMPORTANT: On initial start-up or if maintenance has been performed on the burner assembly, it will be necessary to bleed the air from the gas line before the pilot will light.

7. If you are running the machine for the first time, or have performed maintenance on the burner assembly, there will be air in the gas line. To bleed the air from the gas line run the pressure washer with pump and burner switches on and thermostat on highest setting. Squeeze the trigger of the trigger gun for 15 seconds. If the burner has not ignited, release the trigger for 5 seconds, then squeeze for 15 seconds. If the burner has not ignited after 10 tries, see the **Troubleshooting Guide** in this manual.

CAUTION: Have a qualified gas serviceman install and service your equipment.

DANGER: Never expose a spark or flame where there may be unburned gas present.

DANGER: Some gases are heavier than air and will spill out on the floor in the 2 to 3 minutes required for the safety pilot valve to close off gas supply. Therefore, always provide adequate space and ventilation around these units.

To Start

WARNING: Risk of injection or severe injury - Keep clear of nozzle - DO NOT direct discharge stream at persons - This machine is to be used only by qualified operators.

AVERTISSEMENT: RISQUE D'INJECTION ET DE BLESSURES GRAVES. SE TENIR À L'ÉCART DU JET. NE PAS DIRIGER LE JET DE SORTIE VERS D'AUTRES PERSONNES. CONFIER L'UTILISATION DE CE MATÉRIEL À UN OPÉRATEUR QUALIFIÉ.

WARNING: Wear eye, ear, hand, foot and skin protection at all times while operating pressure washer.

WARNING: Before changing pressure nozzle, engage manual trigger gun lock.

IMPORTANT: The water must be turned on before starting. Running the pump dry will cause damage and void warranty.

IMPORTANT: Do not allow the machine to run with trigger of the trigger gun released for more than 10 minutes at any one time or damage to pump may occur.

1. Turn ON water supply.
2. Turn ON gas supply.
3. Hold wand firmly, release trigger of trigger gun and turn pump switch ON. Squeeze trigger of trigger gun and allow air to purge from system.
4. If HOT water is desired, adjust the thermostat to the proper temperature and turn burner switch ON. Squeeze trigger of trigger gun. The pilot will automatically light, quickly followed by the firing of the burner ring. When the trigger of the trigger gun is released or when the thermostat temperature setting is reached, the burner will automatically turn off.

IMPORTANT: If ignition or flame failure is experienced, discontinue use of pressure washer at once. Turn off burner and shut off fuel supply. Have cause of failure corrected by an authorized service technician before use of pressure washer is continued.

OPERATION INSTRUCTIONS

To Clean

WARNING: Risk of injection or severe injury - Keep clear of nozzle - DO NOT direct discharge stream at persons - This machine is to be used only by qualified operators.

AVERTISSEMENT: RISQUE D'INJECTION ET DE BLESSURES GRAVES. SE TENIR À L'ÉCART DU JET. NE PAS DIRIGER LE JET DE SORTIE VERS D'AUTRES PERSONNES. CONFIER L'UTILISATION DE CE MATÉRIEL À UN OPÉRATEUR QUALIFIÉ.

1. Insert detergent inlet line into container of mixed detergent. Open detergent ON/OFF valve. The detergent will be pulled automatically into the system. Allow detergent to reach end of wand before proceeding to step 3.
2. Select pressure nozzle with spray pattern that matches your cleaning needs. Engage manual trigger lock and install selected nozzle.
3. Wash from the bottom to the top, using side to side motions. This washes away heavy dirt and allows the detergent to soak as you work toward the top.
4. Do not wash at a 90° angle to the work (straight at it). This will allow water to splash back at you and reduces your cleaning power. Wash at a 30° to 60° angle to the work. This will allow the water to splash away from you and the water will wash the dirt away faster and easier.
5. Use the width of the spray pattern to wash in a wide path. Overlap spray paths for complete coverage. Wash from side to side, using slow, steady motions.
6. The nozzle should be 12" to 24" from work, closer for tough areas. Be careful on painted or delicate surfaces, the pressure may damage surface if nozzle is too close.
7. Small parts should be washed in a basket and larger, lightweight parts should be clamped down so the pressure does not push them away.
8. Close the detergent ON/OFF valve to permit rinse. Always rinse with cold water after using detergents. Rinse from the top to the bottom to prevent detergent from dripping onto a rinsed area. For the best results, contact your Hotsy dealer to help you select the best detergent for your application.

SHUTDOWN INSTRUCTIONS

To Stop

1. If detergents were used, draw clear water through the detergent line to purge detergent. Failure to do so may clog detergent injector valve.
2. If burner was used, turn OFF burner switch and allow pump to run cold water through coil for several minutes.
3. Turn pump switch OFF.
4. Turn water supply OFF.
5. Squeeze trigger gun open to relieve system pressure.
6. Depress gas control knob slightly and turn to OFF position.
7. Turn off main shut-off valve on gas supply.

STORAGE INSTRUCTIONS

DANGER: Do not store flammable liquids (gasoline, diesel fuel, petroleum, solvents, etc.) near pressure washer, or in non-ventilated areas.

IMPORTANT: Machine must be stored indoors.

1. Protect from freezing by storing in a heated area, or by flushing the system with antifreeze (use an automotive engine antifreeze or windshield washer solvent to antifreeze). To flush the system fill the float tank with antifreeze and remove pressure nozzle from wand. Start the machine and allow it to run until antifreeze runs from the end of the wand. Place wand into float tank and circulate the solution through system for several minutes. Open and close the trigger gun several times to circulate antifreeze through the unloader valve system. Also draw antifreeze through the detergent inlet line to antifreeze the detergent system. For added protection after antifreezing, disconnect the pressure hose from machine and remove the coil drain plug (refer to **Component Identification** illustration for location). After coil has drained, replace pressure hose and coil drain plug. If the pressure washer is not to be used for an extended length of time, it is recommended that the system be flushed with antifreeze for rust protection.

MAINTENANCE

WARNING: Unauthorized machine modification or use of non-approved replacement parts may cause personal injury and/or property damage and will void the manufacturer warranty.

Pump

Use Hotsy Pump Oil (8.914-527.0) for pump crankcase. Crankcase must be filled to the full mark on the dipstick or to center of sight glass window found on the rear of the pump. During the break-in-period, make sure the oil is changed after the first 25 hours of operation. After that, replace oil every 3 months or 300 hours of operation, whichever comes first.

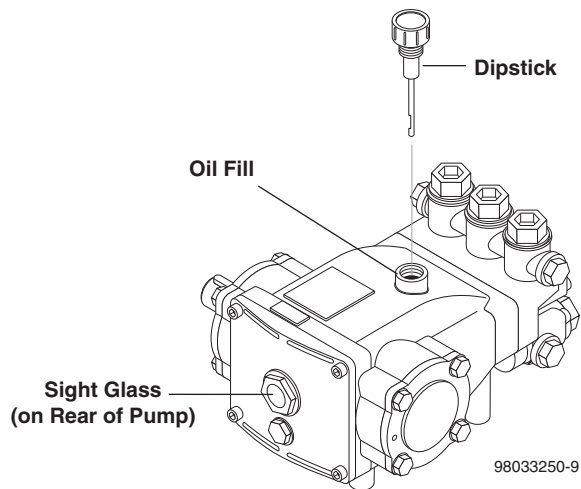

Proper Pump Care:

- Do not pump acids.
- Do not allow pump to run dry.
- Winterize if storing in freezing temperatures; refer to **Storage** for details.
- Use a water softener on the water system if known to be high in mineral content.
- Use only high quality detergents and follow manufacturer's mix recommendations.
- Flush the system with clear water immediately after using detergent solutions.

- Clean filter screen on detergent inlet line periodically.
- Flush the pressure washer system with antifreeze if storing for an extended period of time; refer to **Storage** for details.

Pump Motor

On a yearly basis, oil pump motor per instructions on motor nameplate.

NOTE: Some motors may be equipped with permanently lubricated bearings and will not require additional lubrication.

Gas Burner

It is recommended that the gas burner be serviced yearly or as needed. Contact your local service center.

Relief Valve

WARNING: The relief valve on this pressure washer has been factory set and sealed and is a field nonadjustable part. Tampering with the factory setting may cause personal injury and/or property damage, and will void the manufacturer warranty.

Unloader Valve

WARNING: The unloader valve on this pressure washer has been factory set and sealed and is a field nonadjustable part. Tampering with the factory setting may cause personal injury and/or property damage, and will void the manufacturer warranty.

Heating Coil

Coil Descaling: In hard water areas, scale buildup within the heating coil will occur. Scale deposits will decrease the water temperature rise and may eventually clog the heating coil. Contact your local service center when descaling is needed.

Coil Desooting: Poor grades of fuel oil or inadequate combustion air will cause heavy soot buildup on the outside surface of the heating coil. These deposits will insulate the coil. This will restrict the air flow through the coil, further aggravating the soot buildup. Contact your local service center when desooting is needed.

SMART RELAY INSTRUCTIONS

DIGITAL TIMER (OPTIONAL)

The following are instructions on how to set the parameters on the digital timer in Programming Mode. To define these settings please follow the steps below.

Setting the Clock:

1. Press the **ESC** key located next to the display window and under the arrow key pad (see figure below). Pressing the **ESC** key will access the Parameter Assignment Menu.

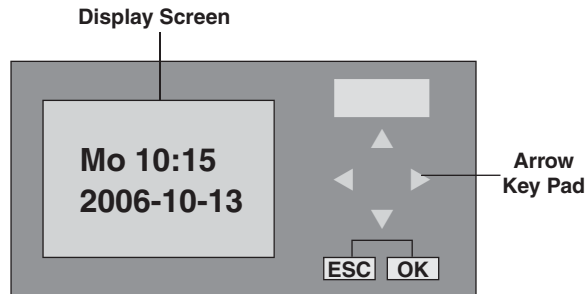

2. Using the up/down arrow keys ▲ or ▼, move the

```

Stop
Set Param
> Set..
Prg Name
  
```

(>) cursor to 'Set' and press **OK** to accept.

```

> Clock
Contrast
StartScreen
  
```

3. Move the (>) cursor to 'Clock' and press **OK** to accept.

```

> Set Clock
S/W Time..
Sync
  
```

4. Move the (>) cursor to 'Set Clock' and press **OK** to accept 'Set Clock'.

NOTE: When setting time on clock, use only *milli-tary time*.

The cursor is now positioned on the weekday and shows the following on the display window (see figure below).

```

Set Clock
Mo 10:15
YYYY-MM-DD
2006-10-13
  
```

5. Select the day of the week by using the up/down arrow keys ▲ or ▼.
6. Move the cursor to the next position by using the left/right arrow keys ◀ or ▶.
7. To change the value use the up/down arrow keys ▲ or ▼.
8. To set the correct time-of-day and date, repeat steps 6 and 7.
9. To accept your entries press **OK**.
10. To go back to the previous menu at anytime press **ESC**.

PROGRAMMING INSTRUCTIONS

The 900/1400 can be configured to run in Time Delay or Auto Start/Stop with lockout. Machines are factory set with Auto Start/Stop with 4 hour Lockout. A Smart Relay controls how the machine will operate by using three internal timers; these timers are adjustable. The following is a brief description of these timers:

Timer 1: 'Lockout Timer' (Time Delay)

- Timer 1 de-energizes (lockout) the machine if not being used for a preset time. If machine has 'Locked out' it can only be re-energize by pressing the 'Pump On' switch. Timer 1 is factory set to 4 hours.

Timer 2: 'Auto Start/Stop Timer'

- Timer 2 allows the pump to run in bypass for a preset time. If the pump runs in bypass longer than the allotted time the timer will drop power to the motor contactor and machine will be in standby mode. Squeezing the gun trigger will restart the pump (if Timer 1 has not locked out). Timer 2 is factory set to 30 seconds.

Timer 3: 'Reset Delay Timer'

- Timer 3 controls how long the pump must run before resetting the 'Lockout Timer' (Timer 1). This allows the pump to run long enough to re-pressurize the system if there is pressure loss when not in use. Timer 3 is factory set to 15 seconds.

SMART RELAY INSTRUCTIONS

PROGRAMMING INSTRUCTION CONT.

To change to the parameters of the internal timers in the Smart Relay complete the following steps:

1. Turn on the power to the machine but do not press the start switch. Remove the front panel and then the control panel cover. **NOTE: Use extreme CAUTION when reaching into the control box, the machine has live power.** Once powered the Smart Relay window will display the following screen, see figure 1 (if screen does not appear press the left/right arrow keys ◀ or ▶ until correct screen appears).

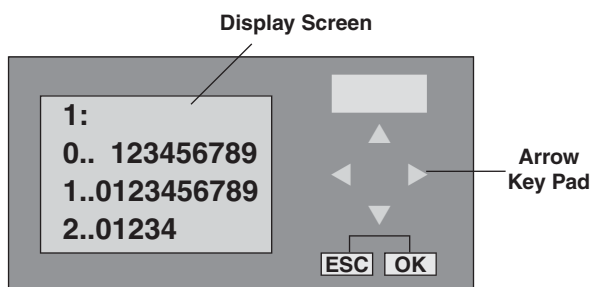

Fig. 1

2. Press the ESC key located next to the display window and under the arrow key pad (see figure 2). Pressing the ESC key will access the Parameter Assignment Menu.
3. Using the up/down arrow key ▲ or ▼, move the (>) cursor to 'Set Param' and press OK to confirm (See figure 3). The display window shows the first parameter (Timer-1), see figure 4.

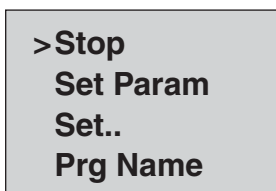

Fig. 2

NOTE: Ta is the accumulator timer and T is the adjustable timer (the variable that changes)

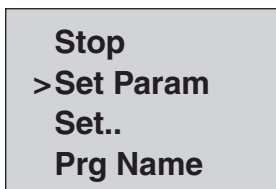

Fig. 3

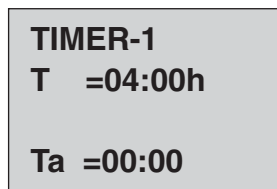

Fig. 4

4. Press OK to change the value of Timer-1. Using the left/right arrow key ◀ or ▶, move the cursor to the desired field and use the up/down arrow keys ▲ or ▼ to change this value. See figure 5.

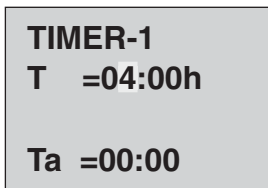

Fig. 5

5. Each timer has optional units of time in seconds (s), minutes (m), and hours (h). To change the unit of time use the left/right arrow keys ◀ or ▶ to move the cursor to the unit field. Change the unit of time using the arrow up/down keys ▲ or ▼. Once all the values have been set press OK to accept. See figure 6.

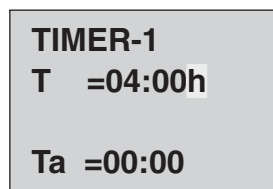

Fig. 6

6. Press arrow up/down keys ▲ or ▼ to select the next parameter to change (Timer-2). Repeat steps 4 and 5 to change the Timer-2 parameters. See figure 7.

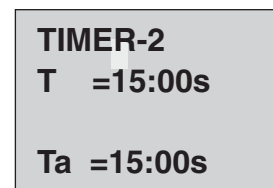

Fig. 7

7. Press arrow up/down keys ▲ or ▼ to select the next parameter to change (Timer-3). Repeat steps 4 and 5 to change the Timer-3 parameters. See figure 8.

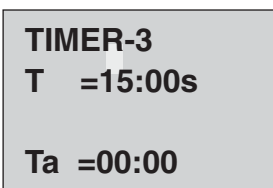

Fig. 8

8. Once all timers have been set to the desired time press ESC twice to return to the Input display screen. See figure 9.

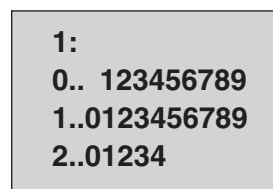

Fig. 9

SMART RELAY INSTRUCTIONS

Factory Set Parameters (Auto Start/Stop with Lockout)

TIMER	VALUE	DESCRIPTION
Timer 1	04:00 Hours	Turns machine off after 4 hours of non-use. To restart push the 'Pump On' switch.
Timer 2	30:00 Seconds	Pump will run in bypass for 30 seconds before shutting off, machine is still in standby mode. Pulling the gun trigger will restart the pump.
Timer 3	15:00 Seconds	In case of pressure loss when machine is in standby, the pump can run up to 15 seconds before resetting 'Timer 1' (lockout)

Time Delay Parameters

TIMER	VALUE	DESCRIPTION
Timer 1	03:00 Minutes	When machine is not in use, pump will run in bypass for 3 minutes and shut off. To restart push the 'Pump On' switch.
Timer 2	01:00 Hours	To operate in time delay mode timer 2 must be deactivated. This is done by setting timer 2 to value greater than timer 1.
Timer 3	15:00 Seconds	Pump must run more than 15 seconds to reset timer 1.

OPTIONAL — WATER INLET SOLENOID

A water inlet solenoid can be added to the machine that will open only when the machine is running or in standby. The solenoid closes when the machine is off to prevent possible water overflow when unattended.

Installation

- Connect a 24V/AC normally closed solenoid on the water inlet, contact local Hotsy dealer for solenoid options.
- Connect solenoid to the remote terminal using 16 ga minimum wire
- Wire solenoid to remote terminal according to figure below

Before powering up machine, fill float tank to prime the system.

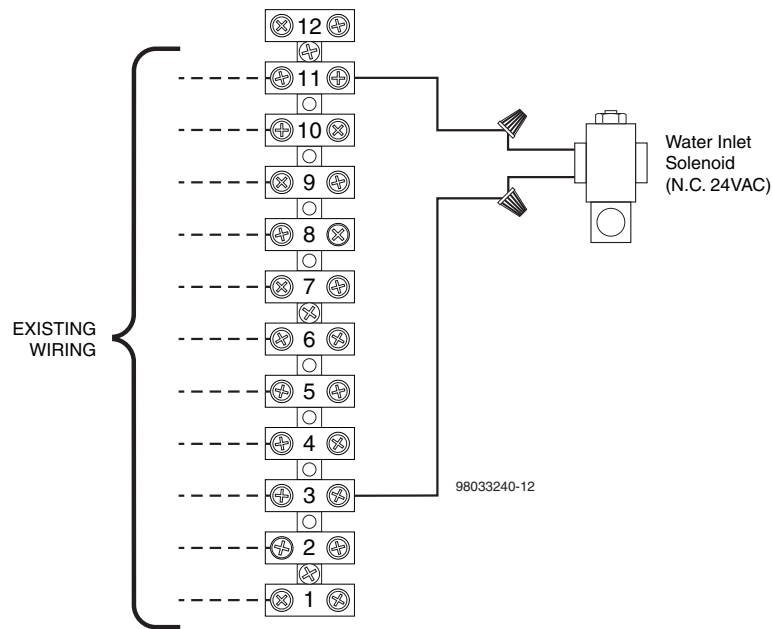

Water Inlet Solenoid Wiring Schematic
(Remote Terminal Located Inside Machine)

Water Inlet Solenoid Wiring Schematic

FRAME BOLT-UP ASSEMBLY EXPLODED VIEW

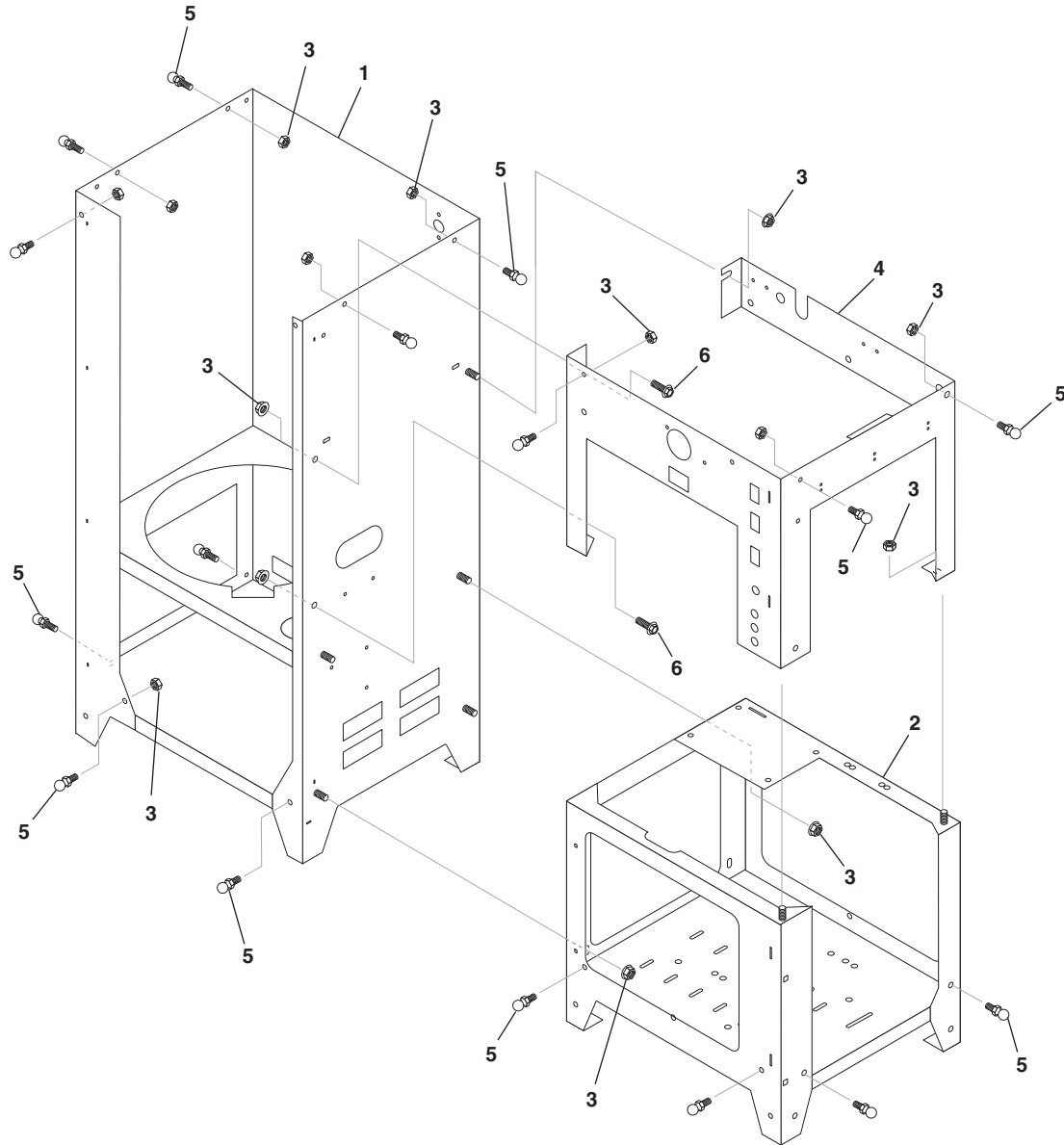

98033240-2

FRAME BOLT-UP ASSEMBLY PARTS LIST

ITEM	PART NO.	DESCRIPTION	QTY
1	8.920-765.0	WLMT, Coil BRNR Box	1
2	8.923-171.0	WLMT, Power Cube Base	1
3	9.802-778.0	Nut, 5/16" Whiz Lock	25

ITEM	PART NO.	DESCRIPTION	QTY
4	8.920-783.0	Frame, Control Panel ,Top	1
5	8.753-254.0	Ball Stud, 5/16"	16
6	9.803-551.0	Screw, 5/16" x 3/4 Whiz Loc	2

BURNER BOX ASSEMBLY EXPLODED VIEW

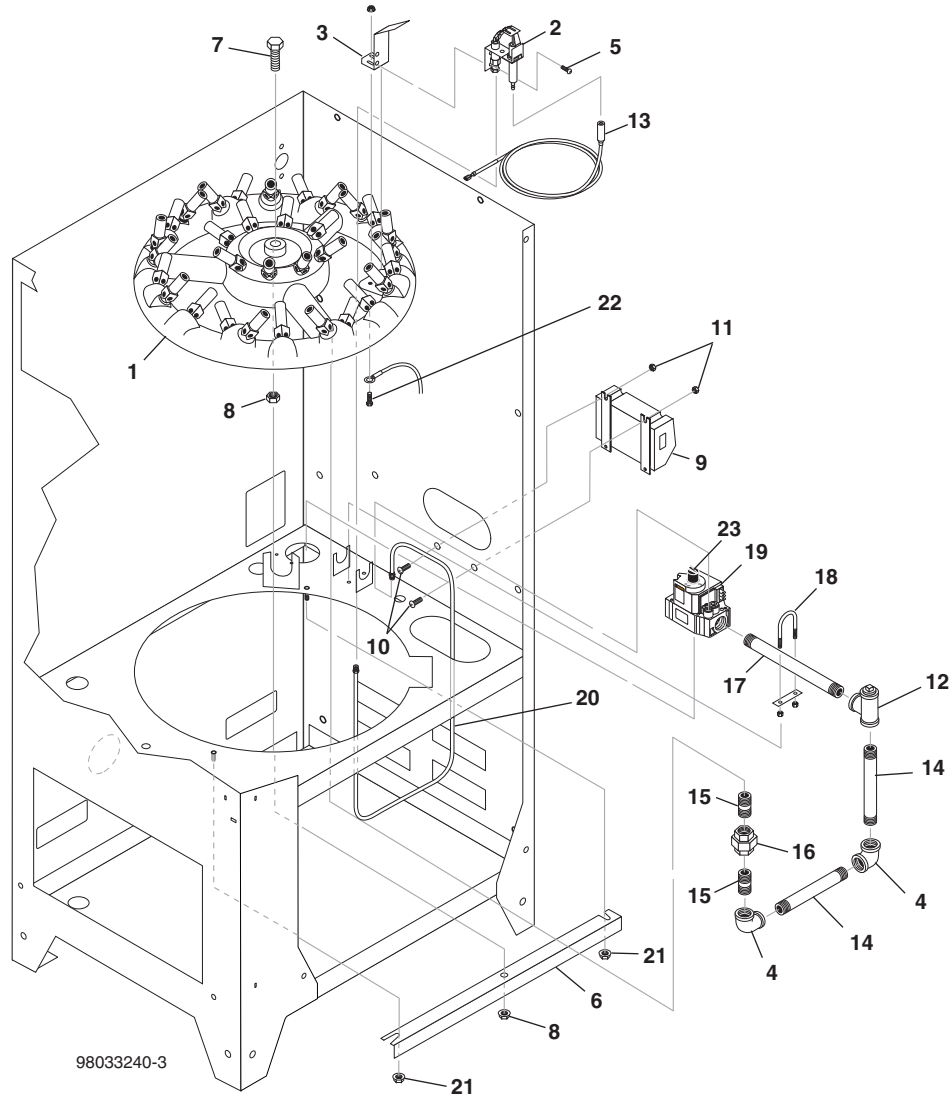

BURNER BOX ASSEMBLY PARTS LIST

ITEM	PART NO.	DESCRIPTION	QTY	ITEM	PART NO.	DESCRIPTION	QTY
1		Burner Ring See Spec. Pages		15	9.802-019.0	Nipple, Black Pipe 3/4" x 2"	2
2	9.803-610.0	Pilot, Ignitor, NG, LP	1	16	9.802-049.0	Union, 3/4" Blk Pipe	2
3	8.719-957.0	Bracket, Pilot Light	1	17	9.802-021.0	Nipple, Black Pipe 3/4" x 9"	1
4	8.802-027.0	Elbow, 90° Black	2	18	9.802-718.0	U-Bolt 5/16" x 1-1/2"	1
5	9.802-772.0	Screw, 10/32" x 1/4" HWH ROLOC, ZN	2	19	9.803-616.0	Valve, 3/4" NG, 24V 3.5 Honeywell	1
6	8.920-780.0	Bracket, BRNR Ring, Support	1	20	9.802-911.0	Tube, Alum, 600"/RL1/4" 37-961464, PER	36"
7	9.802-769.0	Screw, 3/8" x 1-3/4" Whiz Loc	1	21	9.802-778.0	Nut, 5/16", Whiz Loc	2
8	9.802-781.0	Nut, 3/8" NC, Whiz Loc	2	22	8.718-582.0	Bolt, 1/4" x 1/2" NC, HH	1
9	9.803-613.0	Module, Ignition Elec Honeywell	1	23	9.803-618.0	LP, Conversion Kit (943P, 944P, 942P, 945P, 1453P, 1454P, 1452P, 1455P)	1
10	8.718-762.0	Screw, 8/32" x 1-1/4" PHD	4				
11	9.802-785.0	Nut, 8/32" Keps	4				
12	8.706-222.0	Tee, 3/4" Blk Pipe	1				
13	8.920-908.0	Cable, Ignition, 36"	1				
14	9.803-561.0	Nipple, Black Pipe 3/4" x 5"	2				

COIL ASSEMBLY EXPLODED VIEW

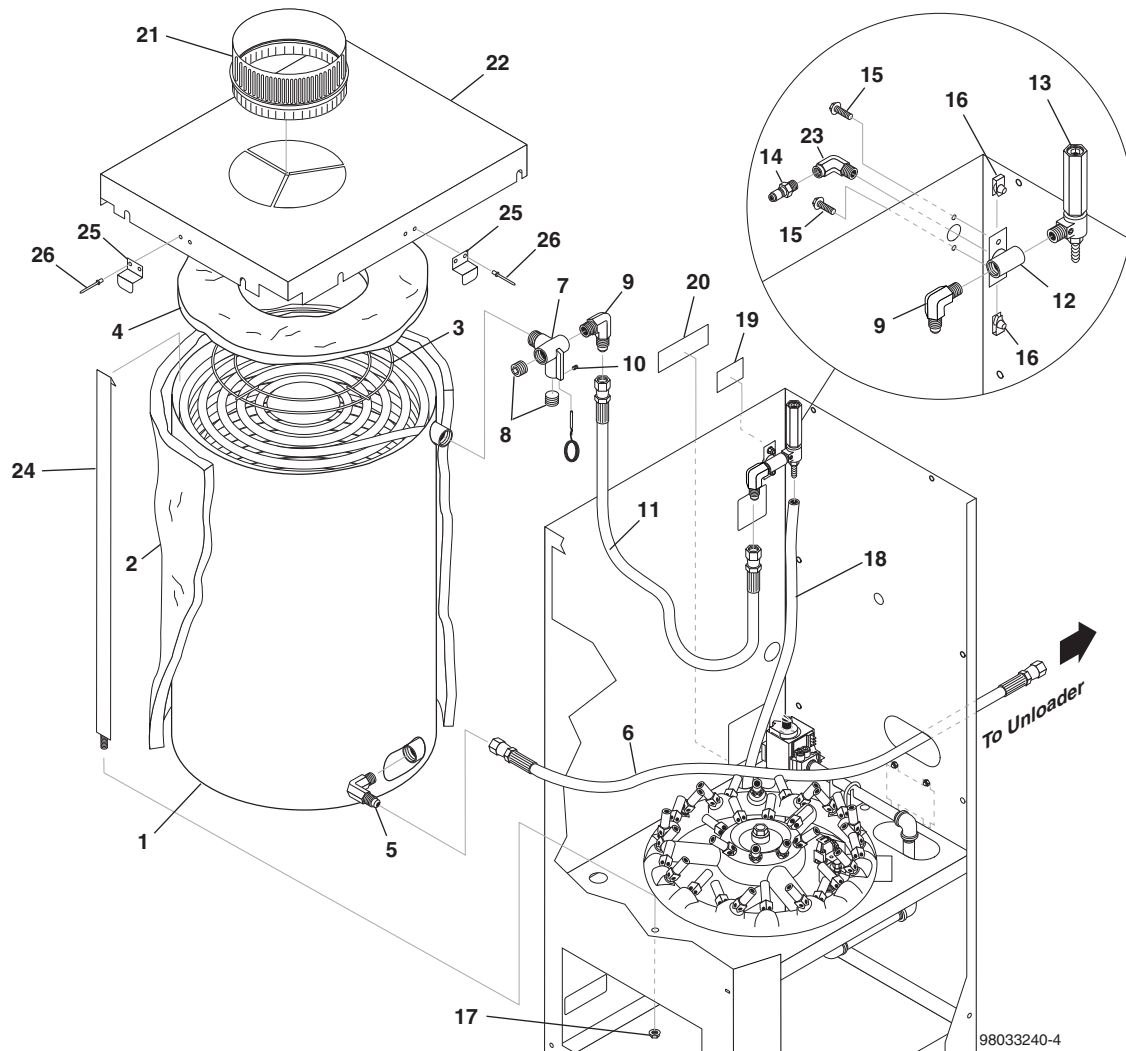

98033240-4

COIL ASSEMBLY PARTS LIST

ITEM	PART NO.	DESCRIPTION	QTY	ITEM	PART NO.	DESCRIPTION	QTY
1	8.911-498.0	Coil Gas 18", Weldment	1	13	8.902-433.0	Valve, Safety Relief VSA	1
2	8.717-518.0	Insulation, 30.75" x 59.0" Fiberglass	1	14	9.802-171.0	Coupler, 3/8" Plug, Male Steel/Zinc	1
3	9.803-108.0	Ring, Insulation Retainer 16" Top Hat	1	15	9.803-551.0	Screw, 5/16" x 3/4" Whiz Loc	2
4	8.717-442.0	Insulation, Top Head, 18OD X 8.0ID, Fiberglass	1	16	8.718-897.0	Nut, 5/16" Speed	2
5	9.802-040.0	Elbow, 1/2" JIC, 1/2" 90°	1	17	9.802-776.0	Nut, 5/16-18 ESNA, NC	2
6	8.918-422.0	Hose, 3/8" x 20", Wire Pressure Lo	1	18	8.711-785.0	Hose, 3/8" Push-On	42"
7	9.149-003.0	Manifold Coil Outlet Discharge	1	19	9.800-021.0	Label, Hot Water Outlet	1
8	8.706-248.0	Plug, 3/8" Allen Counter Sunk	2	20	9.800-858.0	Label, Natural Gas	1
9	9.802-039.0	Elbow, 1/2" JIC x 3/8" MPT	2	21	8.753-166.0	Exhaust, Outlet Ring	1
10	9.196-012.0	Screw, 10-24 x 1/4" Hex Set	1	22	8.920-779.0	Plate, Coil Top, Outlet	1
11	8.918-425.0	Hose, 3/8" x 29", Wire Pressure Lo	1	23	8.706-207.0	Elbow, 3/8", Street	1
12	8.920-781.0	Weldment, Coil Outlet, Bolt On	1	24	8.920-963.0	WLDMT, Strap	2
				25	8.922-407.0	Bracket, DoorLock 900-1400	2
				26	8.751-055.0	Rivet, Alum, 3/16"	4

PUMP & UNLOADER ASSEMBLY EXPLODED VIEW

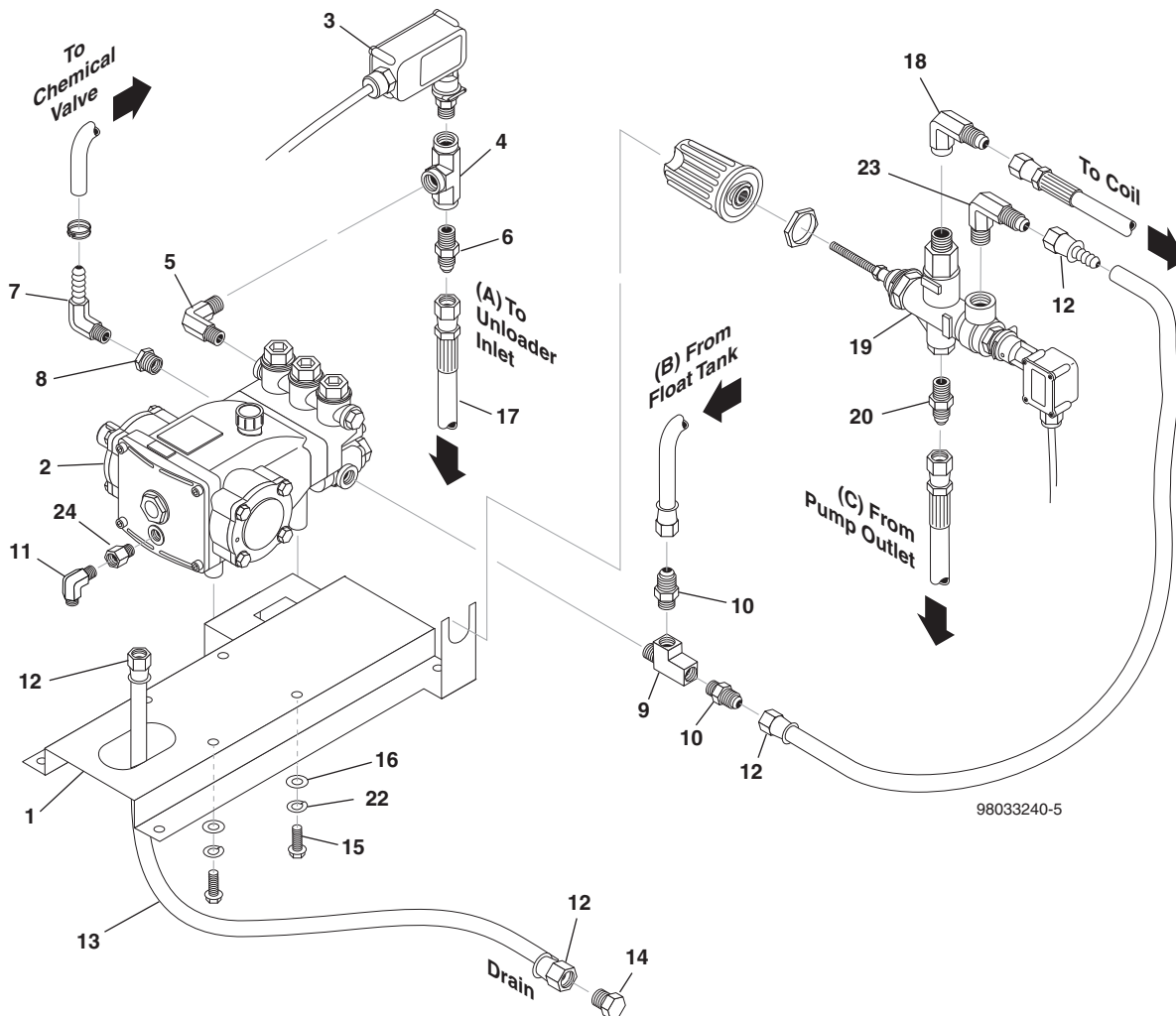

PUMP & UNLOADER ASSEMBLY PARTS LIST

ITEM	PART NO.	DESCRIPTION	QTY	ITEM	PART NO.	DESCRIPTION	QTY
1	8.923-172.0	Plate, Pump Base	1	13	9.802-259.0	Hose, 1/2" Push-On	20"
2		Pump, See Specification Pages	1	14	8.802-126.0	Plug, 1/2" JIC Flare, 639F-8	1
3	8.716-125.0	Switch, Pressure N/O NPT, SS, 65"	1	15	9.802-740.0	Bolt, 10mm x 20mm HH, Zinc	4
4	8.706-214.0	TEE, 3/8" x FPT P/N-TF3709X6	1	16	9.802-807.0	Washer, 3/8" Flat, Zinc	4
5	8.706-168.0	Elbow, 3/8" MPT P/N-TF3529X6	1	17	8.918-424.0	Hose, 3/8" x 25" 2 Wire Pressure	1
6	9.802-036.0	Nipple, 1/2" JIC x 3/8" NPT, Steel	1	18	9.802-129.0	Elbow, 1/2" x 3/8"	1
7	8.706-958.0	Hose Barb, 1/4" Barb x 1/4" MPT, 90°	1	19	8.715-489.0	Unloader, YVB9KMSS, W/S.S/AutoStart	1
8	8.706-915.0	Bushing, 1/2" x 1/4" Brass	1	20	9.802-036.0	Nipple, 1/2" JIC x 3/8" Steel	1
9	8.706-860.0	Tee, 1/2" Street, Brass	1	21	9.802-259.0	Hose, Push-On	14"
10	9.802-128.0	Nipple, 1/2" JIC x 1/2" MPT	2	22	8.718-961.0	Washer, M10 Split Ring	4
11	9.802-129.0	Elbow, 1/2" MSAE x 3/8" Brass	1	23	9.802-043.0	Elbow, 1/2" JIC x 1/2" Fem 90°	1
12	9.802-151.0	Swivel, 1/2" Barb x 1/2" JIC	4	24	8.706-993.0	Adapter, 3/8" x 3/8" (for 1.109-711.0, -712.0, -713.0 and -714.0, -952.0, 953.2 Only)	1

FLOAT TANK ASSEMBLY EXPLODED VIEW

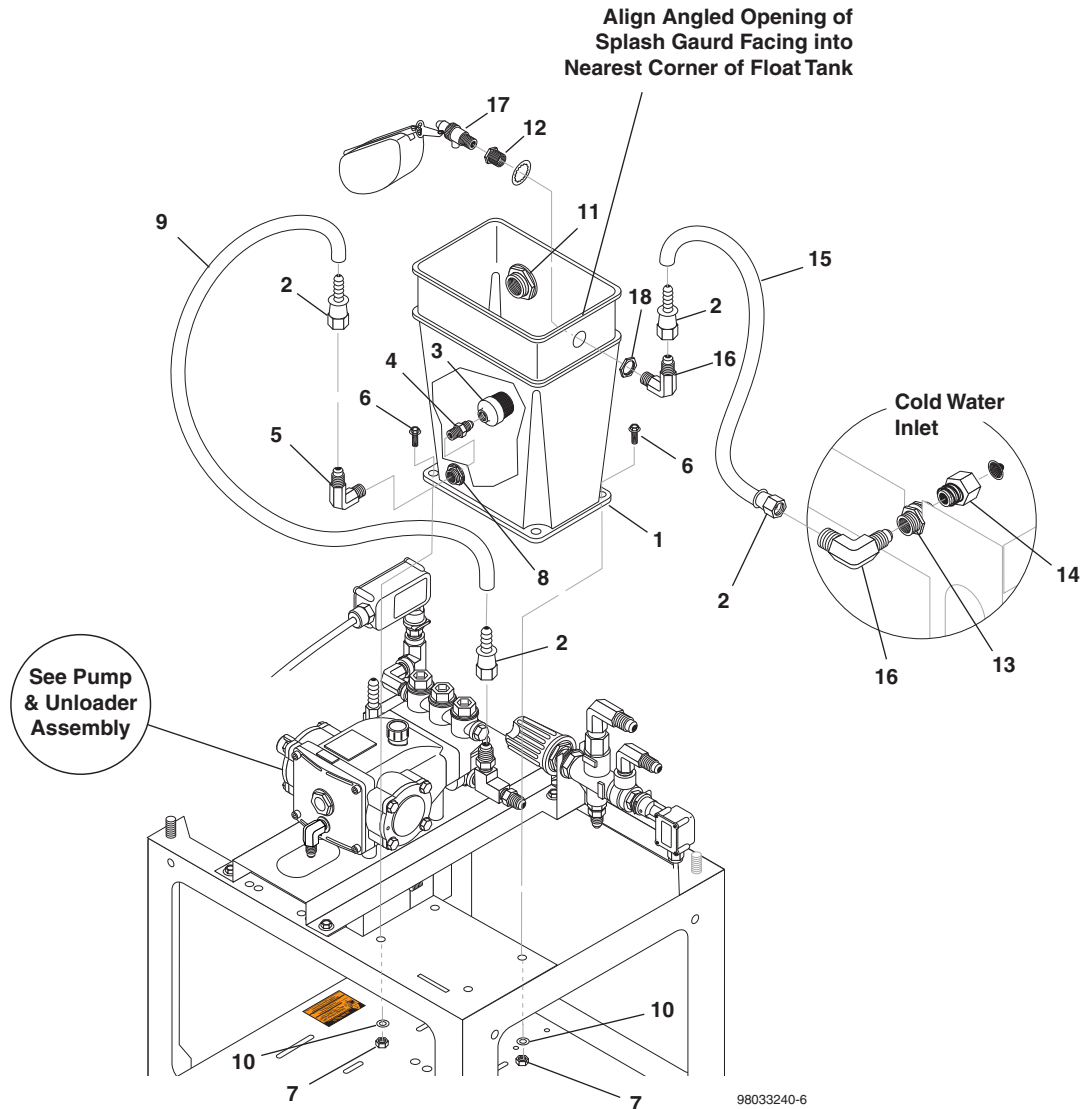

FLOAT TANK ASSEMBLY PARTS LIST

ITEM	PART NO.	DESCRIPTION	QTY	ITEM	PART NO.	DESCRIPTION	QTY
1	8.753-176.0	Tank, 2.6 Gallon	1	10	8.718-959.0	Washer, #10 Flat, SS	4
2	9.802-151.0	Swivel, 1/2" Barb x 1/2" JIC Female, Brass	2	11	8.706-484.0	Bulkhead, 1" Polypro	1
3	8.707-061.0	Strainer, 1/2" Basket (935168)	1	12	8.707-311.0	Adapter, Float Valve, Hotsy	1
4	9.802-128.0	Nipple, JIC 1/2" x 1/2" MPT, Pipe	1	13	8.707-000.0	Connector, 1/2" Anchor	1
5	9.802-131.0	Elbow, 1/2" MSAE x 1/2" MPT	1	14	9.802-146.0	Swivel, 1/2" MP x 3/4" GHF w/Strainer	1
6	9.802-764.0	Screw, 10/32" x 3/4", Hex	4	15	8.711-785.0	Hose, 3/8" Push-On	6"
7	8.718-860.0	Nut, 10/32", ESNA, SS	4	16	9.802-131.0	Elbow, 1/2" MSAE x 1/2" MPT	1
8	8.750-743.0	Bulkhead, 1/2" Polypro	1	17	8.707-310.0	Valve, Float Brass, Hotsy	1
9	9.802-259.0	Hose, Push-On	14"	18	8.754-789.0	Nut, 1-8, Hex, Grade A Zinc	1

TENSIONER ASSEMBLY EXPLODED VIEW

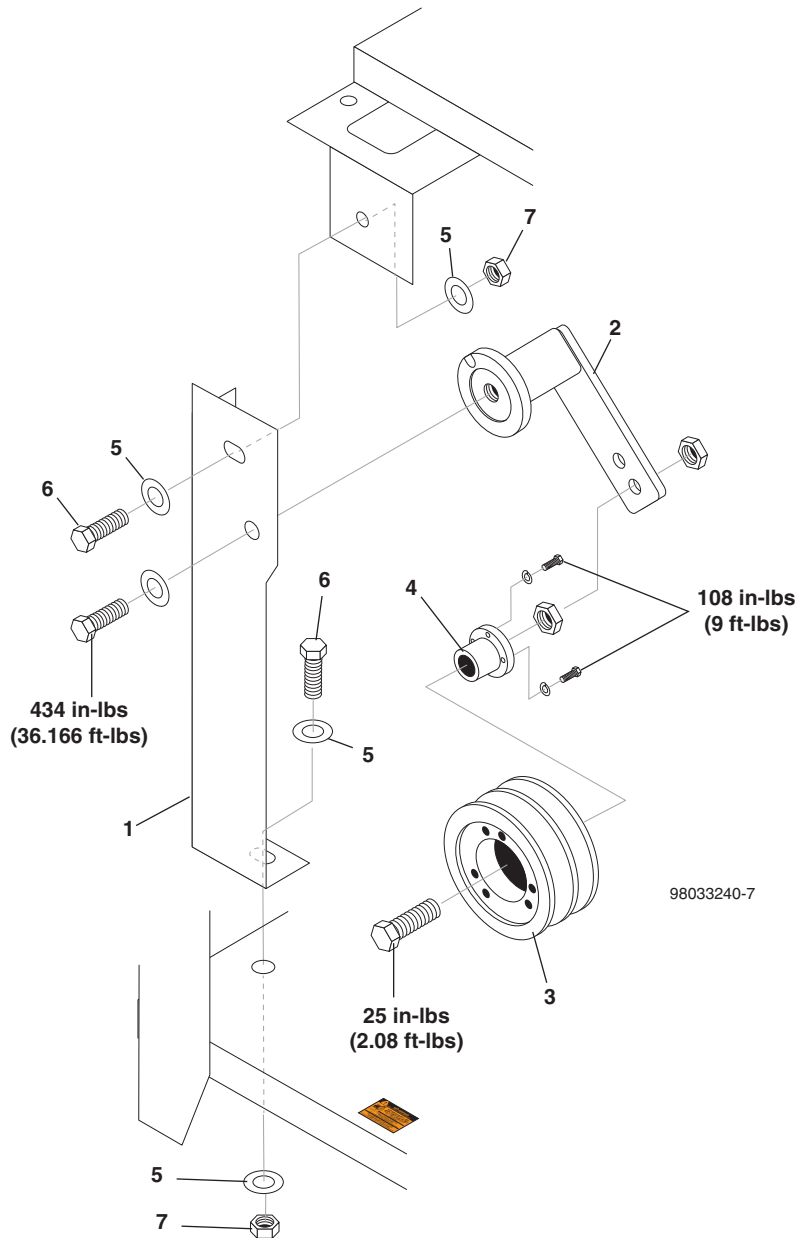

TENSIONER ASSEMBLY PARTS LIST

ITEM	PART NO.	DESCRIPTION	QTY	ITEM	PART NO.	DESCRIPTION	QTY
1	8.923-174.0	Bracket, Idler, Rosta	1	5	9.802-807.0	Washer, 3/8", SAE Flat Zinc	4
2	8.749-975.0	Tensioner, Rosta, SE18, Belt	1	6	9.802-720.0	Bolt, 3/8" x 1" NC HH	2
3	8.753-273.0	Pulley, 2B36 SH	1	7	9.802-779.0	Nut, 3/8", ESNA NC	2
4	8.749-973.0	Bushing, Idler Tension	1				

ELECTRICAL BOX ASSEMBLY EXPLODED VIEW

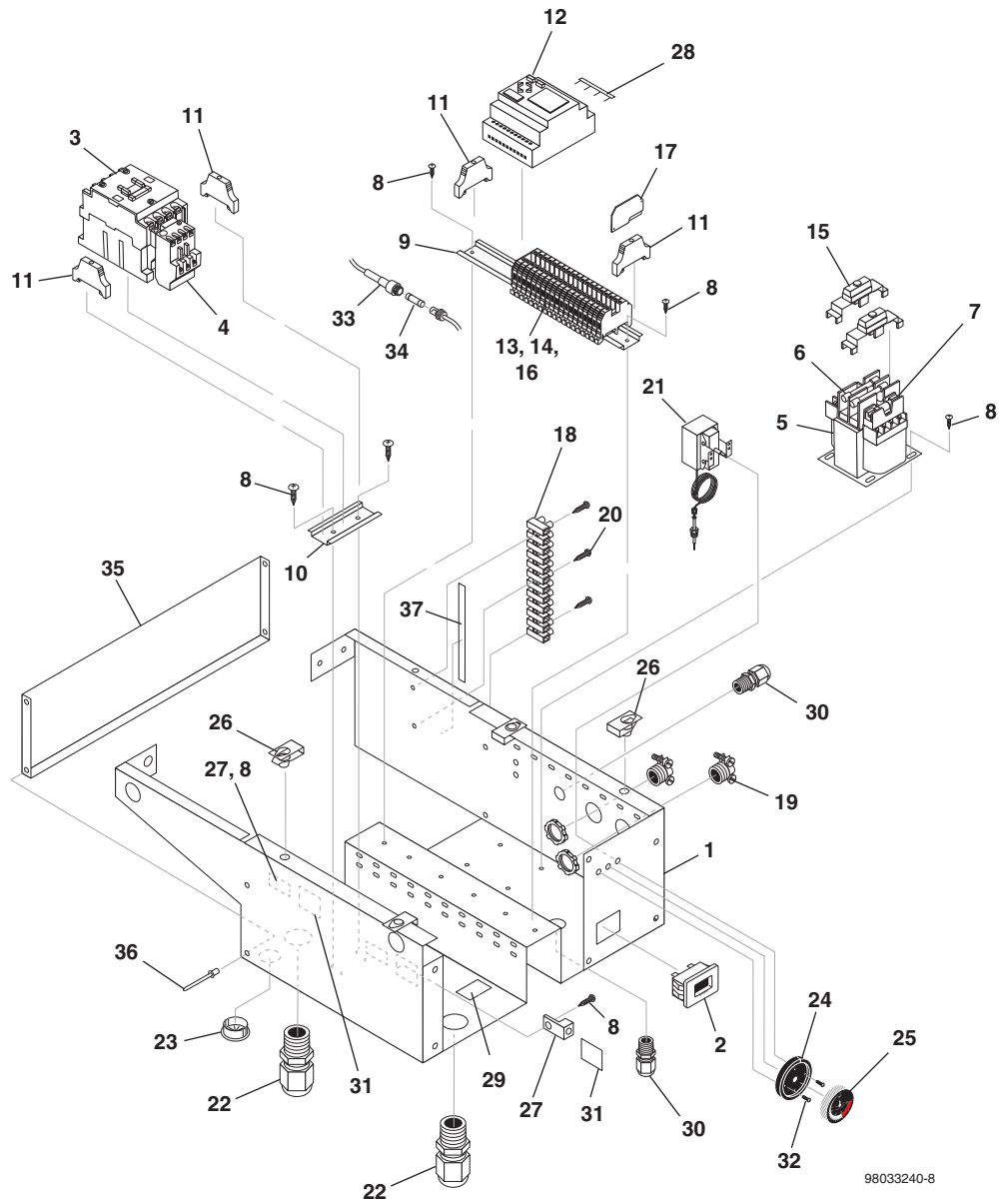

98033240-8

ELECTRICAL BOX PARTS LIST

ITEM	PART NO.	DESCRIPTION	QTY	ITEM	PART NO.	DESCRIPTION	QTY
1	8.922-757.0	Box, Electrical	1	17	8.753-252.0	Terminal Block, End Cap	1
2	9.802-283.0	Hour Meter, 24-240VAC 50/60	1	18	6.643-249.0	Terminal, Strip	1
3		Contactora, See Specification Pages		19	9.802-519.0	Strain Relief, 1/2", Metal	2
4		Overload, See Specification Pages		20	8.718-937.0	Screw, #8 x 3/4" Phillips, Zinc PLTD	3
5		Transformer, See Spec. Pages		21	8.750-095.0	Thermostat, 120C/248F 2 Meter Capillary	1
6		Fuse, See Specification Pages		22	9.802-518.0	Strain Relief, 3/4"	1
7	8.716-199.0	Fuse, FNM-6.25	1		9.802-521.0	Strain Relief, 3/4" Pur (1743),(1474N, 1474P)	2
8	8.718-936.0	Screw, #8 x 1/2" Phillips Zinc Tek	10	23	8.706-755.0	Bushing, .875, P/N 2119	1
9	9.802-457.0	Din Rail, 35mm	10"	24	8.712-190.0	Bezel, Plastic	1
10	9.802-457.0	Din Rail, 35mm	3"	25	9.750-097.0	Knob, Thermostat 120C/248F	1
11	9.804-595.0	End Bracket, Entrelec 103-002-26	4	26	8.718-897.0	Nut, 5/16" Speed	4
12	8.755-622.0	Relay, Smart, 24V, 8I/4O	1	27	8.716-460.0	Terminal, Grounding Lug	2
13	7.749-976.0	Terminal Block Feed Through, Phoenix, 3 Wire	5	28	8.921-218.0	Q BAR, PLC	1
14	8.753-064.0	Terminal Block Feed Through, Phoenix, 2 Wire	11	29	8.900-514.0	Label, Voltage, 208V, 1 PH (921N, 1451N)	1
15	8.716-449.0	Cover, Fuse Protector	2		9.800-025.0	Label, Voltage, 230V,1PH, (943P, 943N,1453P, 1453N,1473P,1473N)	1
16	8.749-977.0	Bar, Jumper, FSB 2-5GY	3		8.900-515.0	Label, Voltage, 208V, 3 PH (942P, 942N, 1452P, 1452N)	1
					9.800-023.0	Label, Voltage, 230V 3 PH, (944P, 944N, 1454P, 1454N,1474P,1474N)	1
					9.800-024.0	Label, Voltage, 460V, 3 PH (945P, 945N, 1455P, 1455N)	1
					8.900-516.0	Label, Voltage, 575V, 3 PH (926N, 1456N)	1
				30	8.716-598.0	Strain Relief, .18-.31	2
				31	9.800-040.0	Label, Ground Symbol	3
				32	8.718-779.0	Screw, 4mm x 6mm	2
				33	8.716-216.0	Holder, Fuse	1
				34	8.716-170.0	Fuse, MDL-1/2 250V Fuse	1
				35	8.922-969.0	Bracket, Back, E-Box	1
				36	8.751-055.0	Rivet, Alum 3/16" Dia. 062-.125 Grip	4
				37	9.801-488.0	Label, Terminal Block, 12 Pin	1
				38	9.803-471.0	▲ PLC Logic, Hotsy	1

▲ Not Shown

COMPONENT CUBE ASSEMBLY EXPLODED VIEW

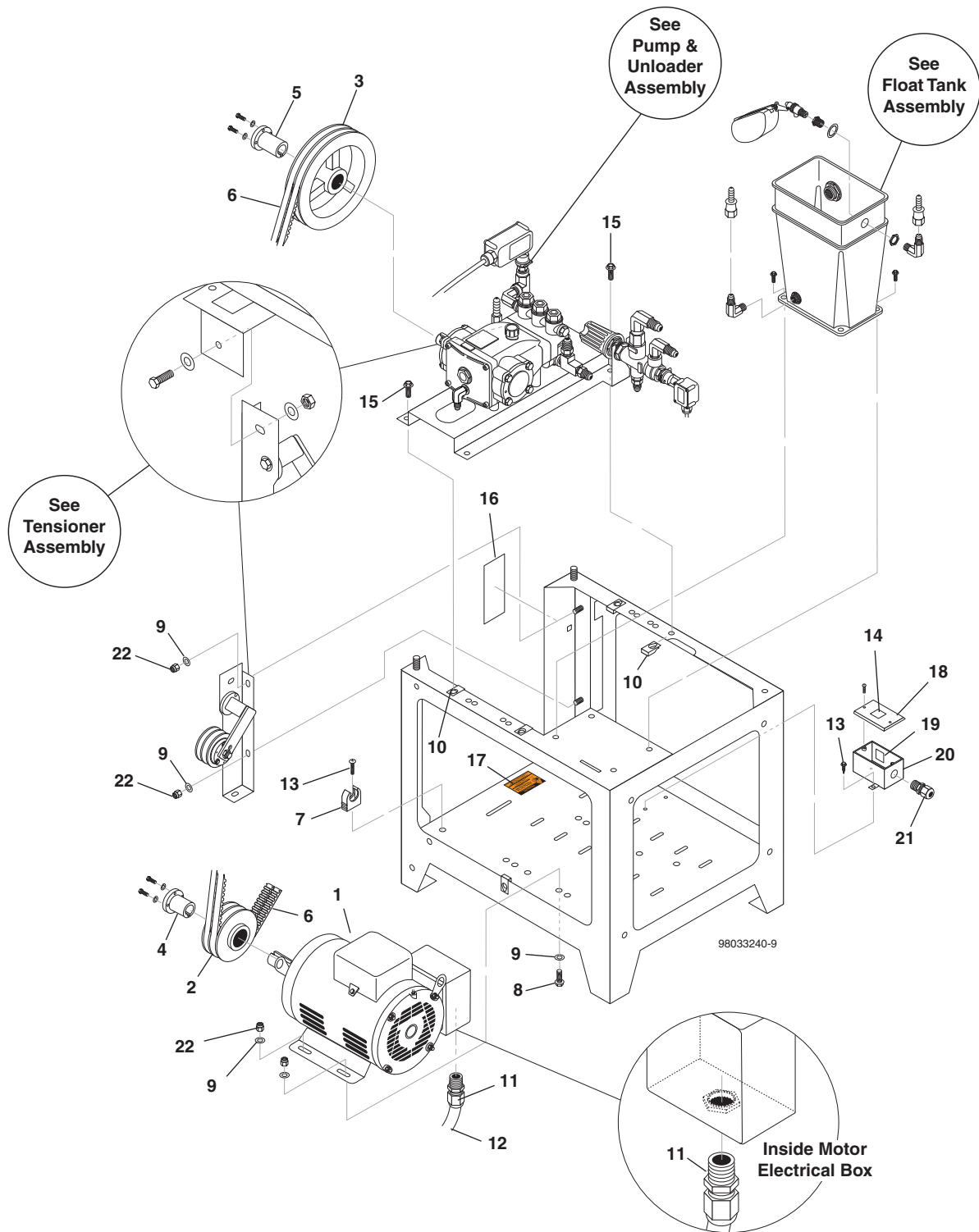

COMPONENT CUBE ASSEMBLY PARTS LIST

ITEM	PART NO.	DESCRIPTION	QTY	ITEM	PART NO.	DESCRIPTION	QTY
1		Motor, See Specifications Pgs	1	13	8.718-760.0	Screw, #8 x 3/4" Phillips	3
2		Pulley, See Specifications Pgs	1	14	8.900-514.0	Label, Voltage, 208V, 1 PH (921N, 1451N, 921P, 1451P)	1
3		Pulley, See Specifications Pgs	1		9.800-025.0	Label, Voltage, 230V, 1 PH (943P, 943N, 1453P, 1453N,1473P,1473N)	1
4		Bushing, See Specifications Pgs	1		8.900-515.0	Label, Voltage, 208V, 3 PH (942P, 942N, 1452P, 1452N 1475P, 1475N)	1
5	9.802-402.0	Bushing, H x 24mm	1		9.800-023.0	Label, Voltage, 230V 3 PH (944P, 944N, 1454P, 1454N,1474P,1474N)	1
6		Belt, See Specifications Pgs	2		9.800-024.0	Label, Voltage, 460V, 3 PH (945P, 945N, 1455P, 1455N)	1
7	9.802-203.0	Clamp, 1/2"	1		8.900-516.0	Label, Voltage, 575V, 3 PH (926N, 1456N, 926P, 1456P)	1
8	9.802-720.0	Bolt, 3/8" x 1" NC HH	4	15	9.803-551.0	Screw, 5/16 x 3/4" Whiz Loc	4
9	9.802-807.0	Washer, 3/8" SAE, Flat Zinc	16	16	8.921-205.0	Label, Motor Rotation	1
10	8.718-897.0	Nut, 5/16" Speed	4	17	8.932-965.0	Label, Warning, Exposed Pulley	1
11	9.802-518.0	Strain Relief, (921N, 921P, 926N 926P, 942N, 942P, 943N, 943P, 944N, 944P, 945N, 945P, 1451N, 1451P, 1456N, 1456P)	1	18	9.802-483.0	Cover, 2" x 4" Metal Weather Proof	1
	8.753-364.0	Strain Relief, (1452N, 1452P, 1453N, 1453P, 1454N, 1454P, 1455N, 1455P, 1474N, 1474P, 1475N, 1475P)	1	19	9.800-040.0	Label, Ground Symbol	1
	8.753-363.0	Locknut 1" (1452N, 1452P, 1453N, 1453P, 1454N, 1454P, 1455N, 1455P, 1474N, 1474P, 1475N, 1475P)	1	20	8.716-339.0	Elec Box, 4" x 2"	1
	9.802-521.0	Strain Relief, (1473N, 1473P)	1	21	8.753-364.0	Strain Relief	1
	9.802-523.0	Locknut, (1473N, 1473P)	1		9.803-279.0	Strain Relief (944N, 944P, 1456N, 1456P)	1
12	9.802-429.0	Cord, Serv, 12/4 (926N, 942N, 945N, 1455N, 1456N, 926P, 942P 944P, 945P, 1455P, 1456P)	45"		9.803-280.0	Locknut (944N, 944P, 1456N, 1456P)	1
	9.802-436.0	Cord, Service, 10/3 (921N, 943N, 921P, 943P)	45"	22	9.802-779.0	Nut, 3/8" ESNA, NC	6
	9.802-437.0	Cord Service, 10/4 (1452N, 1454N, 1452P, 1454P)	45"				
	9.802-425.0	Cord, Service 8/3 (1451N, 1453N, 1451P, 1453P)	45"				
	9.804-048.0	Cord, Service, 6/3 (1473P, 1473N)	45"				
	9.802-426.0	Cord, Service, 8/4 (1474P, 1475P, 1474N, 1475N)	45"				

POWER SIDE ASSEMBLY EXPLODED VIEW

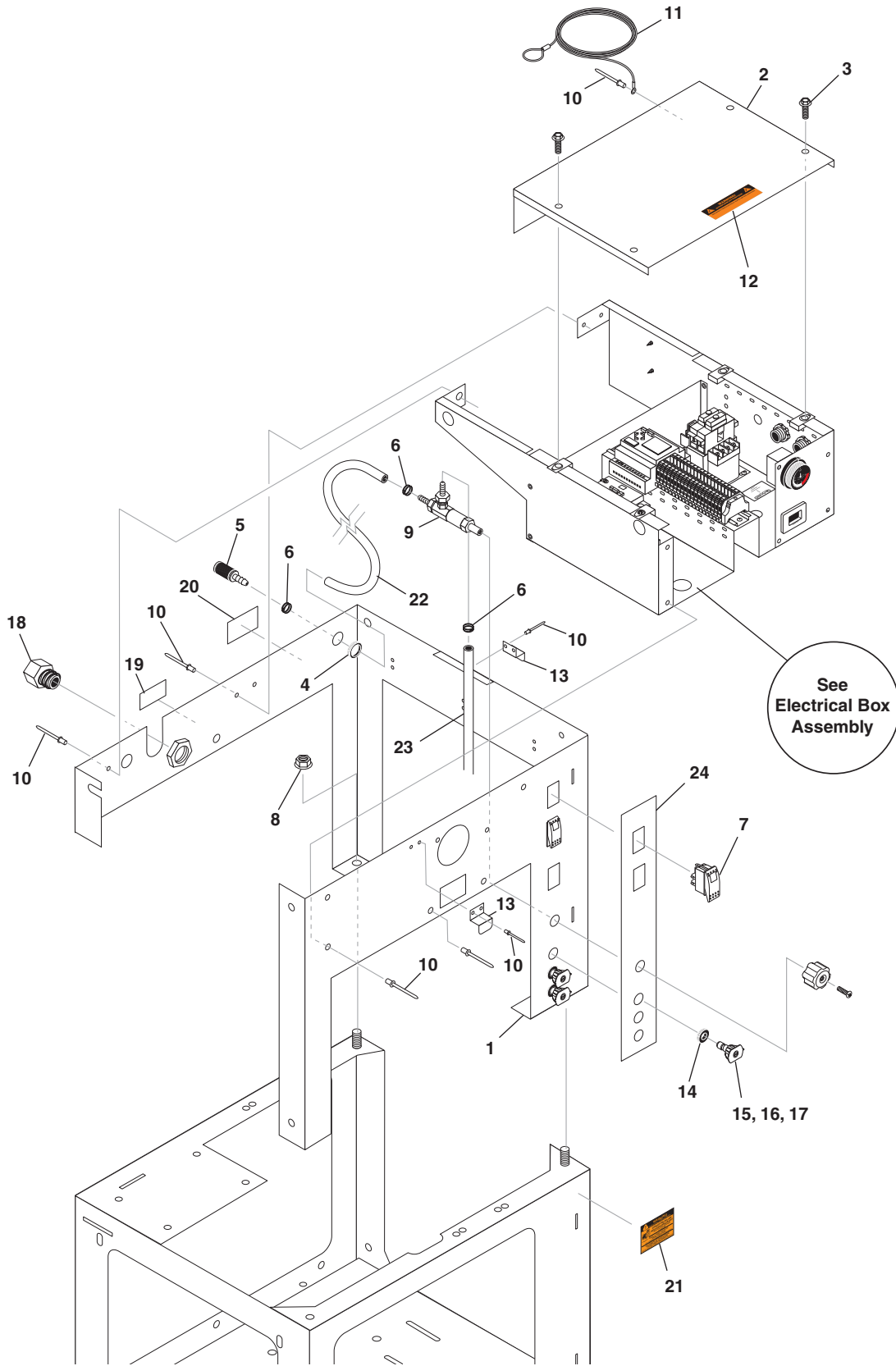

98033240-10

POWER SIDE ASSEMBLY PARTS LIST

ITEM	PART NO.	DESCRIPTION	QTY
1	8.920-783.0	Frame, Control Panel, Top	1
2	8.920-778.0	Lid, Electrical Box Cover	1
3	9.802-754.0	Screw, 1/4" x 1" Whiz Loc	4
4	9.802-103.0	Bushing, 5/8" Snap	1
5	8.707-058.0	Strainer, 1/4" Brass W/Check Valve	1
6	6.390-126.0	Clamp, Hose, .46-, .54 ST	3
7	8.716-037.0	Switch, Rocker 10A/250V-15A/125V, 24VLT	2
8	9.802-778.0	Nut, 5/16" Whiz Loc	2
9	9.082-188.0	Valve, Metering, 1/4" Hose	1
10	8.751-055.0	Rivet, Alum, 3/16" Dia	14
11	8.624-608.0	Laynard, 18.0 w/Loop & Eye	1
12	9.800-016.0	Lable, Disconnect Power	1
13	8.922-407.0	Bracket, Door Lock 900-1400	2
14	8.706-547.0	Grommet, Rubber Nozzel Holder	3
15		Nozzle, See pg. 38	1
16		Nozzle, See pg. 38	1

ITEM	PART NO.	DESCRIPTION	QTY
17		Nozzle, See pg. 38	1
18	9.802-146.0	Swivel, 1/2" MP x 3/4" GHF w/Strainer	1
19	9.800-020.0	Label, Cold Water Inlet	1
20	9.800-049.0	Label, Manufacturers Cleaning Solution	1
21	8.932-965.0	Label, Warning, Exposed Pulley	1
22	9.802-252.0	Hose, 1/4" x 1/2" Braided Vinyl	8 ft.
23	9.802-252.0	Hose, 1/4" x 1/2" Braided Vinyl	12"
24	8.921-204.0	Label, Control Panel	1

PANEL & DOORS EXPLODED VIEW

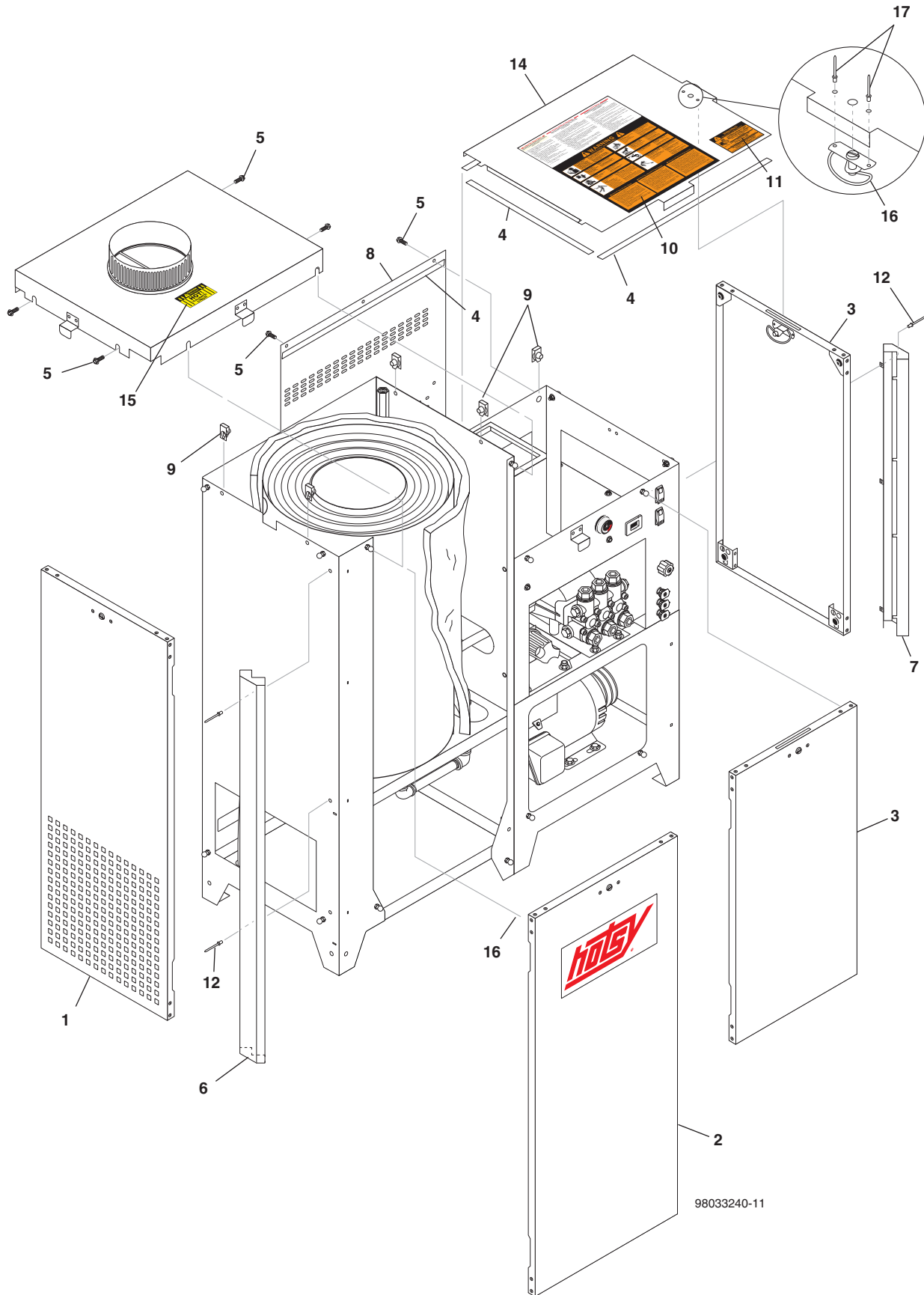

98033240-11

PANEL & DOORS PARTS LIST

ITEM	PART NO.	DESCRIPTION	QTY
1	8.924-153.0	Assy, Panel, Side Coil	1
2	8.924-154.0	Assy, Panel, Front Coil	1
3	8.924-155.0	Assy, Panel, Front Coil	2
4	9.802-073.0	Weather Strip, 1/8" x 1/2"	11.5
5	9.803-551.0	Screw, 5/8" x 3/4", Whiz Loc	13
6	8.902-773.0	Bracket, Corner Edge, Coil End	1
7	8.902-772.0	PMP Corner, Edge, PMP End	1
8	8.923-350.0	Panel, Rear Cover	1
9	8.718-897.0	Nut, 5/16" Speed	6
10	8.900-990.0	Label, Instructions, Warnings	1

ITEM	PART NO.	DESCRIPTION	QTY
11	8.932-965.0	Label, Warning, Exposed Pulley	1
12	8.751-055.0	Rivet, Aluminum 3/16" DIA. 062-.125 Grip	42
13	9.706-548.0	▲ Grommet, 2-1/2"	1
14	8.920-777.0	Lid, Pump Motor, Cover	1
15	9.800-006.0	Label, Hot/Caliente	1
16	8.719-081.0	Latch, Spring, Flush Head	1
17	9.804-301.0	Rivet, 1/8" x 1/4"	2

▲ Not Shown

HOSE, GUN & WAND ASSEMBLY

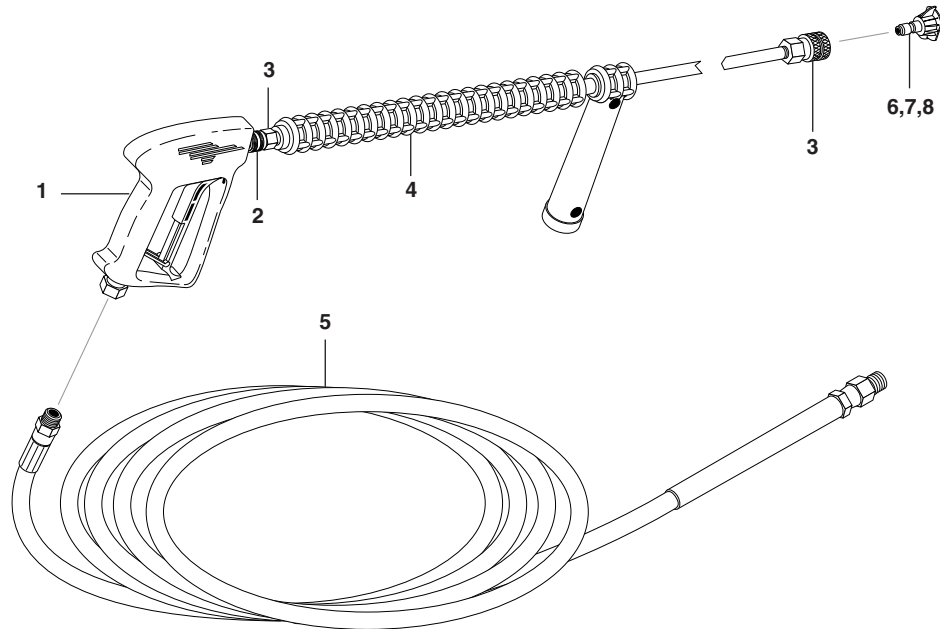

HOSE, GUN & WAND ASSEMBLY PARTS LIST

ITEM	PART NO.	DESCRIPTION	QTY	ITEM	PART NO.	DESCRIPTION	QTY
1	8.751-235.0	Gun, Hotsy, H1050, 5000 PSI, 10.4 GPM	1	8	8.712-352.0	Nozzle, 4.5 White (1400 Series)	1
2	8.707-139.0	Nipple, 1/4" x 1/4" NPT ST Male	1		8.712-360.0	Nozzle, 5.5 White (943P, 943N, 944P, 942P, 944N, 942N, 945P, 945N)	1
3	9.802-164.0	Coupler, 1/4" Female, Brass	2		8.712-356.0	Nozzle, 5.0 White (921N, 926N)	1
4	8.725-389.0	Wand, Single, 36" Insulated, w/Side Grip	1	REPLACEMENT PARTS			
5	8.917-061.0	Hose, 3/8" x 50', 2-Wire, Tuff Skin	1		8.701-663.0	Valve Assembly, Unitized	1
6	8.712-349.0	Nozzle, 4.5 Red (1400 Series)	1				
	8.712-357.0	Nozzle, 5.5 Red (943P, 943N, 944P, 942P, 944N, 942N, 945P, 945N)	1				
	8.712-353.0	Nozzle, 5.0 Red (921N, 926N,)	1				
7	8.712-350.0	Nozzle, 4.5 Yellow (1400 Series)	1				
	8.712-358.0	Nozzle, 5.5 Yellow (943P, 943N, 944P, 942P, 944N, 942N, 945P, 945N)	1				
	8.712-354.0	Nozzle, 5.0 Yellow (921N, 926N)	1				

TROUBLESHOOTING

SYMPTOM	POSSIBLE CAUSES	CORRECTIVE ACTION
PRESSURE WASHER WILL NOT RUN	Pump switch in OFF position	Place switch in ON position.
	Power supply disconnected	Connect power supply.
	Fuse blown or circuit breaker tripped in electrical supply line	Replace fuse or reset circuit breaker. Use only circuits of adequate capacity.
	Motor circuit overload tripped	Allow sufficient time for motor to cool down. Place pump switch in ON position.
PRESSURE WASHER RUNS BUT WON'T SPRAY	Trigger of trigger gun released	Squeeze trigger.
	Water supply not turned on	Open water supply valve.
	Clogged pressure nozzle	Clean pressure nozzle opening.
	Inlet water screen clogged	Check screen and clean if necessary.
	Pump sucking air	Fill the detergent container and check for loose hose clamps or fittings.
LOW SPRAY PRESSURE AT NOZZLE	Inadequate water supply	Fully open faucet. Check for kinked or damaged hose. Use 5/8" minimum hose. Check for debris clogging inlet screen.
	Partially clogged or damaged pressure nozzle	Clean or replace.
	Air being drawn through detergent inlet line	Refill detergent container. Ensure that pick-up screen is fully immersed.
UNEVEN SPRAY PATTERN	Partially clogged or damaged pressure nozzle	Clean or replace.
PRESSURE WASHER WILL NOT PRODUCE HOT WATER	Burner switch in OFF position	Place switch in ON position.
	Gas valve switch in OFF position	Place switch in ON position.
	Inadequate fuel supply	Check fuel supply.
	Pump switch turned off	Pump must be running before burner will light.

TROUBLESHOOTING

SYMPTOM	POSSIBLE CAUSES	CORRECTIVE ACTION
PRESSURE WASHER WILL NOT PRODUCE HOT WATER (Continued)	Inadequate water supply	Fully open faucet. Check for kinked or damaged hose. Use 5/8" minimum hose. Check for debris clogging inlet screen.
	Trigger of trigger gun released	Squeeze trigger. Water must be spraying for burner to light.
	Thermostat set too low, or defective	Raise thermostat setting. Replace if defective.
	Manual gas valve not open	Turn ON gas valve.
	Defective gas valve	Replace gas valve.
POOR OR NO DETERGENT FLOW	Inadequate detergent supply	Refill detergent container. Ensure that pick-up screen is fully immersed.
	Detergent screen or hose clogged	Clean. Always start with a clean detergent container.
	Clogged detergent injector check valve	Clean check valve at detergent injector.
POOR CLEANING	Improper detergent concentration or mixing	Mix detergent per manufacturer's instructions. Ensure that powdered detergents are fully dissolved.
	Wrong detergent for the application	Select appropriate detergent.
	Rinsing with hot water	A final rinse with cold water will reduce water spotting.
	Detergent valve not opening	Check that handle or knob is not slipping on shaft.
UNLOADER CYCLES WHEN TRIGGER GUN IS OPENED OR CLOSED	Air in system	Open and close trigger gun several times.
	Unloader defective	Replace if defective.
	Water leak between unloader valve and trigger gun	Check fittings, hose and trigger gun for leaks. Repair or replace.
BURNER SMOKES OR HAS OBNOXIOUS ODOR	Stack restriction	See Venting under Installation.
PRESSURE RELIEF VALVE LEAKING	Excessive pressure due to defective unloader valve	Replace unloader valve.
	Defective relief valve	Replace relief valve.
	Dirty relief valve	Clean relief valve seat

BURNER TROUBLESHOOTING

PROBLEM	POSSIBLE CAUSE	SOLUTION
HAVE PILOT FLAME, MAIN BURNER WILL NOT TURN ON	Faulty main valve coil in the gas valve	Set test meter to 24 volt scale.
	Faulty ignitor/sensor and/or its wiring	With pilot flame on ignitor/sensor, probe terminals MV and MV/PV on the ignition control unit. If you read 24 volts here, but not at the gas valve, there is a loose wiring connection. Repair or replace as needed.
	Ground wire not attached to machine chassis	If you do read 24 volts at MV and MV/PV and the pilot flame is impinging on the ignitor/sensor rod, the problems may be:
	Faulty ignition control unit	a. Faulty ignitor/sensor and/or its wiring.
		b. Faulty ignition control unit.
		Set test meter to the ohm scale. Turn burner switch off.
Check continuity through the green ground wire and its connections.		
Reconnect the ignitor/sensor wire and the ground wire.		
	Turn burner switch on. With the pilot burning and the flame on the ignitor/sensor rod, the main burner should turn on. If it does not, replace the ignition control unit.	
SHORT-CYCLING OF MAIN BURNER. MAIN BURNER TURNS OFF BEFORE THE BURNER SWITCH OR FLOW SWITCH IS TURNED OFF	Draft condition pulls flame from ignitor/sensor rod.	Check the thermostat by bypassing at terminals P1 & 1.
		Set thermostat high. With main burner on, observe the pilot flame impingement on the ignitor/sensor.
	Faulty thermostat or water temperature is too high	If pilot flame is small and draft condition pulls flame from ignitor sensor rod, the burner will turn off and then on again. a. Adjust pilot flame higher or clean pilot orifice. b. Bend ignitor/sensor rod closer to pilot flame.
		If flame impingement on the ignitor/sensor is stable and the system short-cycles, check the limit switch.
		Set test meter to 110 volt scale; a. When the system cycles off, probe the switch terminals of the limit switch. b. If you read 24V across the switch terminals the limit switch is open. Replace the limit switch.
	A pilot flame set too high will also cause burner to short cycle. Pilot flame lifts over ignitor/sensor.	

BURNER TROUBLESHOOTING

PROBLEM	POSSIBLE CAUSE	SOLUTION
FLOW & BURNER SWITCH ON; NO SPARK, NO PILOT GAS	A. No main power	With power switch on, open trigger on spray gun and set your test meter to the 24 volt scale. Probe terminals 24V and 24V(GND). If you do not read 24 volts, the problem is not the ignition system. Perform normal system checks of main power, transformer, thermostat and the limit control. If you do read 24 volts at TH and GND, the problem is in the ignition system. Check for loose or defective wiring. If wiring is good, replace the ignition control unit.
	B. Faulty transformer	
	C. Faulty burner & flow switch	
	D. Faulty ignition control unit	
HAVE SPARK, NO PILOT GAS FLOW	Main gas supply turned off	Set test meter to 24 volt scale.
		1. Be sure main gas valve (gas cock or selector arm) is turned on.
		2. With gas on and system sparking, probe terminals PV and 24V(GND). If pilot gas does not flow with 24 volts at these terminals, replace gas valve.
		3. Probe terminals PV and MV/PV. If 24 volts not present, replace ignition control box.
HAVE PILOT GAS, NO SPARK	A. Defective ignitor/ sensor and or its wiring	Set test meter to ohm scale.
		1. Disconnect the wire from the IGN terminal on the ignition control unit.
	B. Faulty ignition control unit	2. Touch one meter probe to the tip of the ignitor/ sensor rod in the pilot. Touch the other probe to the quick connect at the other end of ignitor/ sensor wire.
		3. If you have continuity from the tip of the ignitor/ sensor rod to the connector and no spark, replace the ignition control unit.
		4. If you do not have continuity through wire and the ignitor/sensor, check for a loose wire connection in the wire. Repair as needed.
		5. Check to see if spark shorts to burner ring through a cut in the ignitor wire.

TROUBLESHOOTING

IMPORTANT

If the pressure washer demonstrates other symptoms or the corrective actions listed do not correct the problem, contact the local authorized Hotsy Service Center. The Hotsy Service Center can be identified by visiting www.hotsy.com.

When ordering from your dealer, please provide the following:

Model Number: _____ **Release:** _____

Machine Serial Number: _____

Component Part Number: _____

Description: _____

GAS-FIRED SERIES OPTIONAL EQUIPMENT

835526 Draft Diverter, 8"

SPECIFICATIONS

Model	Nozzle	Motor	Motor HP	Contactora	Overload	Trans-Former	Pump	Pump Pulley	Belts
943P	5.5	8.715-142.0	5	8.724-280.0	8.724-305.0	9.803-662.0	8.923-165.0	8.715-592.0	8.715-707.0
943N	5.5	8.715-142.0	5	8.724-280.0	8.724-305.0	9.803-662.0	8.923-165.0	8.715-592.0	8.715-707.0
944P	5.5	8.751-013.0	5	8.724-269.0	8.724-304.0	9.803-662.0	8.923-165.0	8.715-592.0	8.715-707.0
942P	5.5	8.715-092.0	5	8.724-269.0	8.724-304.0	9.803-662.0	8.923-165.0	8.715-592.0	8.715-707.0
944N	5.5	8.751-013.0	5	8.724-269.0	8.724-304.0	9.803-662.0	8.923-165.0	8.715-592.0	8.715-707.0
942N	5.5	8.715-092.0	5	8.724-269.0	8.724-304.0	9.803-662.0	8.923-165.0	8.715-592.0	8.715-707.0
945P	5.5	8.751-013.0	5	8.724-269.0	8.724-303.0	8.716-886.0	8.923-165.0	8.715-592.0	8.715-707.0
945N	5.5	8.751-013.0	5	8.724-269.0	8.724-303.0	8.716-886.0	8.923-165.0	8.715-592.0	8.715-707.0
926P	5.5	8.751-009.0	5	8.724-269.0	8.724-303.0	8.716-884.0	8.923-165.0	8.715-592.0	8.715-707.0
926N	5.5	8.751-009.0	5	8.724-269.0	8.724-303.0	8.716-884.0	8.923-165.0	8.715-592.0	8.715-707.0
1453P	4.5	8.715-097.0	7.5	8.724-283.0	8.724-306.0	9.803-662.0	8.923-165.0	8.715-592.0	8.715-706.0
1453N	4.5	8.715-097.0	7.5	8.724-283.0	8.724-306.0	9.803-662.0	8.923-165.0	8.715-592.0	8.715-706.0
1454P	4.5	8.751-014.0	7.5	8.724-275.0	8.724-304.0	9.803-662.0	8.923-165.0	8.715-592.0	8.715-706.0
1452P	4.5	8.715-101.0	7.5	8.724-275.0	8.724-305.0	9.803-662.0	8.923-165.0	8.715-592.0	8.715-706.0
1454N	4.5	8.751-014.0	7.5	8.724-275.0	8.724-305.0	9.803-662.0	8.923-165.0	8.715-592.0	8.715-706.0
1452N	4.5	8.715-101.0	7.5	8.724-275.0	8.724-305.0	9.803-662.0	8.923-165.0	8.715-592.0	8.715-706.0
1455P	4.5	8.751-014.0	7.5	8.724-269.0	8.724-312.0	8.716-886.0	8.923-165.0	8.715-592.0	8.715-706.0
1455N	4.5	8.751-014.0	7.5	8.724-269.0	8.724-312.0	8.716-886.0	8.923-165.0	8.715-592.0	8.715-706.0
921P	5.0	8.715-128.0	6.2	8.724-280.0	8.724-306.0	9.803-662.0	8.751-180.0	9.802-391.0	8.710-761.0
921N	5.0	8.715-128.0	6.2	8.724-280.0	8.724-306.0	9.803-662.0	8.751-180.0	9.802-391.0	8.710-761.0
1451P	4.5	8.715-162.0	8.2	8.724-283.0	8.724-306.0	9.803-662.0	8.751-180.0	8.715-593.0	8.710-761.0
1451N	4.5	8.715-162.0	8.2	8.724-283.0	8.724-306.0	9.803-662.0	8.751-180.0	8.715-593.0	8.710-761.0
1456P	4.5	8.751-005.0	8.2	8.724-269.0	8.724-303.0	8.716-884.0	8.751-180.0	8.715-593.0	8.710-761.0
1456N	4.5	8.751-005.0	8.2	8.724-269.0	8.724-303.0	8.716-884.0	8.751-180.0	8.715-593.0	8.710-761.0
1473P	5.5	8.751-236.0	10	8.724-283.0	8.724-307.0	9.803-662.0	8.751-180.0	9.804-060.0	8.710-756.0
1473N	5.5	8.751-236.0	10	8.724-283.0	8.724-307.0	9.803-662.0	8.751-180.0	9.804-060.0	8.710-756.0
1474P	5.5	8.751-015.0	10	8.724-280.0	8.724-305.0	9.803-662.0	8.751-180.0	9.804-060.0	8.715-705.0
1474N	5.5	8.751-015.0	10	8.724-280.0	8.724-305.0	9.803-662.0	8.750-746.0	9.804-060.0	8.715-705.0
1475P	5.5	8.715-109.0	10	8.724-283.0	8.724-306.0	9.803-662.0	8.750-746.0	9.804-060.0	8.715-701.0
1475N	5.5	8.715-109.0	10	8.724-283.0	8.724-306.0	9.803-662.0	8.750-746.0	9.804-060.0	8.715-701.0

SPECIFICATIONS

Model	Motor Pulley	Motor Bushing	Burner	Pilot	Gas Valve	Fuse (2)
943P	8.715-582.0	9.802-400.0	8.718-056.0	9.803-610.0	9.803-616.0	8.713-286.0
943N	8.715-582.0	9.802-400.0	8.718-055.0	9.803-610.0	9.803-616.0	8.713-286.0
944P	8.715-582.0	9.802-400.0	8.718-056.0	9.803-610.0	9.803-616.0	8.713-286.0
942P	8.715-582.0	9.802-400.0	8.718-056.0	9.803-610.0	9.803-616.0	8.713-286.0
944N	8.715-582.0	9.802-400.0	8.718-055.0	9.803-610.0	9.803-616.0	8.713-286.0
942N	8.715-582.0	9.802-400.0	8.718-055.0	9.803-610.0	9.803-616.0	8.713-286.0
945P	8.715-582.0	9.802-400.0	8.718-056.0	9.803-610.0	9.803-616.0	8.713-080.0
945N	8.715-582.0	9.802-400.0	8.718-055.0	9.803-610.0	9.803-616.0	8.713-080.0
926P	8.715-582.0	9.802-400.0	8.718-055.0	9.803-610.0	9.803-616.0	8.713-080.0
926N	8.715-582.0	9.802-400.0	8.718-055.0	9.803-610.0	9.803-616.0	8.713-080.0
1453P	8.715-582.0	9.802-401.0	8.718-056.0	9.803-610.0	9.803-616.0	8.713-286.0
1453N	8.715-582.0	9.802-401.0	8.718-055.0	9.803-610.0	9.803-616.0	8.713-286.0
1454P	8.715-582.0	9.802-401.0	8.718-056.0	9.803-610.0	9.803-616.0	8.713-286.0
1452P	8.715-582.0	9.802-401.0	8.718-056.0	9.803-610.0	9.803-616.0	8.713-286.0
1454N	8.715-582.0	9.802-401.0	8.718-055.0	9.803-610.0	9.803-616.0	8.713-286.0
1452N	8.715-582.0	9.802-401.0	8.718-055.0	9.803-610.0	9.803-616.0	8.713-286.0
1455P	8.715-582.0	9.802-401.0	8.718-056.0	9.803-610.0	9.803-616.0	8.713-080.0
1455N	8.715-582.0	9.802-401.0	8.718-055.0	9.803-610.0	9.803-616.0	8.713-080.0
921P	8.715-576.0	9.802-400.0	8.718-056.0	9.803-610.0	9.803-616.0	8.713-286.0
921N	8.715-576.0	9.802-400.0	8.718-055.0	9.803-610.0	9.803-616.0	8.713-286.0
1451P	8.715-576.0	9.802-400.0	8.718-056.0	9.803-610.0	9.803-616.0	8.713-286.0
1451N	8.715-576.0	9.802-400.0	8.718-055.0	9.803-610.0	9.803-616.0	8.713-286.0
1456P	8.715-576.0	9.802-400.0	8.718-056.0	9.803-610.0	9.803-616.0	8.713-080.0
1456N	8.715-576.0	9.802-400.0	8.718-055.0	9.803-610.0	9.803-616.0	8.713-080.0
1473P	9.803-299.0	9.802-401.0	8.718-056.0	9.803-610.0	9.803-616.0	8.713-286.0
1473N	9.803-299.0	9.802-401.0	8.718-055.0	9.803-610.0	9.803-616.0	8.713-286.0
1474P	9.803-299.0	9.802-402.0	8.718-056.0	9.803-610.0	9.803-616.0	8.713-286.0
1474N	9.803-299.0	9.802-402.0	8.718-055.0	9.803-610.0	9.803-616.0	8.713-286.0
1475P	9.803-299.0	9.802-402.0	8.718-056.0	9.803-610.0	9.803-616.0	8.713-286.0
1475N	9.803-299.0	9.802-402.0	8.718-055.0	9.803-610.0	9.803-616.0	8.713-286.0

HM.3 SERIES PUMP EXPLODED VIEW

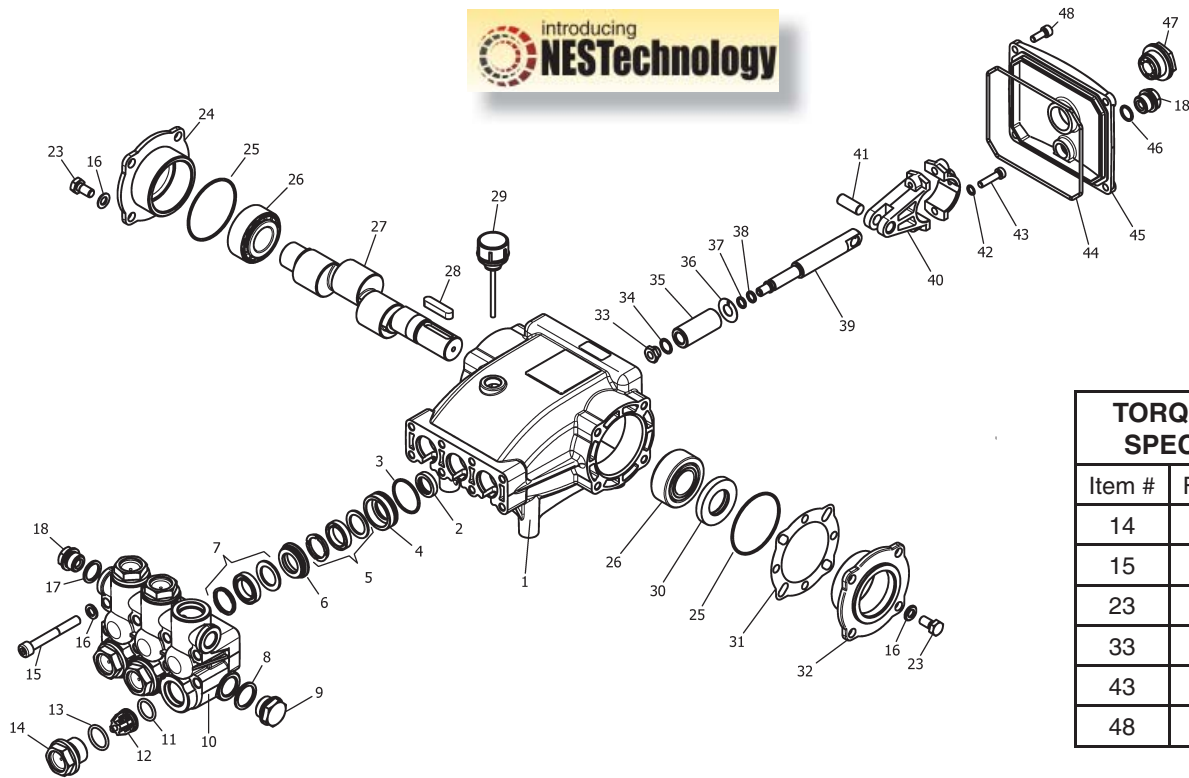

HM.3 SERIES PUMP EXPLODED VIEW PARTS LIST

ITEM	PART NO.	DESCRIPTION	QTY	ITEM	PART NO.	DESCRIPTION	QTY
1	8.751-216.0	Crankcase	1	18	9.802-925.0	Brass Plug 3/8	2
2*	See Kits Below	Plunger Oil Seal	3	23	9.802-944.0	Hexagonal Screw	8
3*	See Kits Below	O-Ring Ø1.78 x 31.47	3	24	8.717-210.0	Closed Bearing Housing	1
4*	See Kits Below	Pressure Ring	3	25	9.803-192.0	O-Ring Ø1.78 x 60.05	2
5*	See Kits Below	U-Seal	3	26	8.933-011.0	Tapered Roller Bearing	2
6*	See Kits Below	Intermediate Ring	3	27	8.751-222.0	Crankshaft (3540)	1
7*	See Kits Below	U-Seal	3		8.751-223.0	Crankshaft (4030, 4035)	1
8	9.803-199.0	Washer, Copper	1		8.717-063.0	Crankshaft (4031)	1
9	9.802-926.0	Plug, Brass 1/2	1	28	9.803-167.0	Crankshaft Key	1
10	8.751-218.0	Manifold Head	1	29	9.802-921.0	Oil Dip Stick	1
11*	See Kits Below	O-Ring Ø2.62 x 17.13	6	30	9.803-140.0	Crankshaft Seal	1
12*	See Kits Below	Valve Assembly	6	31	9.803-178.0	Shim	2
13*	See Kits Below	O-Ring Ø2.62 x 20.29	6	32	8.717-209.0	Bearing Housing	1
14	9.802-928.0	Valve Plug	6	33*	See Kits Below	Plunger Nut, M8	3
15	9.802-938.0	Manifold Stud Bolt	8	34*	See Kits Below	Copper Spacer	3
16	9.802-884.0	Washer	16	35*	See Kits Below	Plunger	3
17	9.803-198.0	Copper Washer 3/8	1	36*	See Kits Below	Copper Spacer	3

HM.3 SERIES PUMP EXPLODED VIEW PARTS LIST

ITEM	PART NO.	DESCRIPTION	QTY
37*	See Kits Below	O-Ring	3
38*	See Kits Below	Teflon Ring	3
39	8.751-224.0	Plunger Rod (4030, 4031, 4035)	3
	8.751-225.0	Plunger Rod (3540)	3
40	9.803-158.0	Connecting Rod	3
41	8.751-228.0	Connecting Rod Pin	3
42	9.803-218.0	Spring Washer	6
43	9.803-238.0	Connecting Rod Screw	6
44	70-060009	O-Ring, Ø2.62 x 126.67	1
45	8.751-229.0	Crankcase Cover	1
46	9.803-197.0	O-Ring, Ø1.78 x 14	1
47	9.803-202.0	Sight Glass 3/4	1
48	9.802-939.0	Cover Screw	5

* Available in kit (See below)

REPAIR KIT NO.	8.725-360.0	8.725-362.0	8.725-358.0	8.725-361.0	8.725-363.0	8.725-359.0	8.751-237.0	8.751-238.0
KIT DESCRIPTION	Plunger Seal 4035 18mm	Plunger Seal 4030, 4031 20mm	Plunger Seal 3540 15mm	Complete Seal Packing 4035 18mm	Complete Seal Packing 4030, 4031 20mm	Complete Seal Packing 3540 15mm	Plunger 4035 18mm	Plunger 4030, 4031 20mm
ITEM NUMBERS INCLUDED	3, 5, 7	3, 5, 7	3, 5, 7	3, 4, 5, 6, 7	3, 4, 5, 6, 7	3, 4, 5, 6, 7	33, 34, 35, 36, 37, 38	33, 34, 35, 36, 37, 38
NO. OF CYLINDERS KIT WILL SERVICE	3	3	3	1	1	1	1	1

REPAIR KIT NO.	8.933-023.0	9.802-603.0	9.802-609.0
KIT DESCRIPTION	Plunger 3540 15mm	Complete Valve	Plunger Oil Seals
ITEM NUMBERS INCLUDED	33, 34, 35, 36, 37, 38	11, 12, 13	2
NO. OF CYLINDERS KIT WILL SERVICE	1	6	3

VB9 UNLOADER EXPLODED VIEW AND PARTS LIST

921580
8.715-489.0

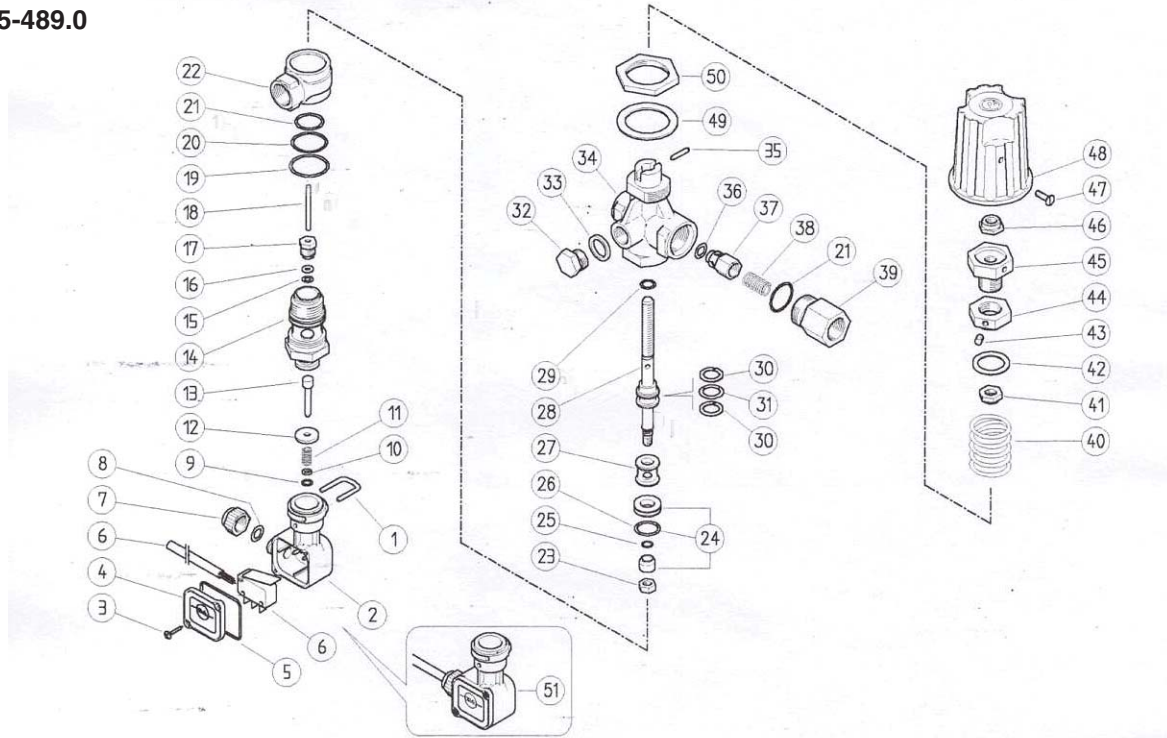

ITEM	PART #	DESCRIPTION	QTY
1	29.0087.51	Sst Clip	1
2	29.0089.84	Plastic Housing	1
3	16.3020.00	2.5 x 12 mm Screw	2
4	29.0088.84	Cover	1
5	10.3206.01*	O-Ring, 2.62 x 28.25mm	1
6	12.5006.00	El. Cable and Microswitch	1
7	29.0109.84	Red Nut (25 Bar)	1
8	10.3169.00*	O-Ring, 2.62 x 6.02 mm	1
9	10.3038.00*	O-Ring, 1.78 x 3.68 mm	1
10	14.3519.00	Washer, 4 x 8 mm	1
11	60.2303.51	Spring	1
12	29.0086.31	Washer, 4 x 16 mm	1
13	60.2351.31	Pin	1
14	60.2353.31	Seat Fitting	1
15	10.3165.00*	O-Ring, 2.62 x 2.84	1
16	10.4018.00*	Back Ring, 3.2 x 7.5 mm	1
17	30.4115.31	M 10 Plug	1
18	60.2352.51	Sst Pin	1
19	10.3073.00*	O-Ring, 1.78 x 23.52 mm	1
20	10.3072.50*	O-Ring, 1.78 x 21.95 mm	1
21	10.3070.02*	O-Ring, 1.78 x 18.77 mm	2
22	60.0733.35	Manifold	1
23	11.4540.00	Sst M6 Nut	1
24	60.2221.20*	VB8/9 Seat and Shutter	1
25	10.3001.01*	O-Ring, 1 x 4 mm	1
26	10.3066.01	O-Ring, 1.78 x 15.6 mm	1

ITEM	PART #	DESCRIPTION	QTY
27	60.2210.31	Spacer	1
28	60.2202.51	VB 9 Piston	1
29	10.3170.08	O-Ring, 2.62 x 7.6 mm	1
30	10.4021.00	Back Ring, 11.4 x 15.9 mm	2
31	10.3175.00	O-Ring, 2.62 x 10.77mm	1
32	28.0013.31	Brass, 1/4 Bsp Plug	1
33	14.3911.00	1/4" Copper Washer	1
34	60.2201.35	VB9 Brass Body	1
35	15.1021.00	Pin 3 x 14 mm	1
36	10.3213.00	O-Ring 3 x 6 mm	1
37	60.0052.31	Check Valve	1
38	60.0053.51	Spring	1
39	60.0058.31	3/8 Bsp F Outlet Fitting	1
40	60.2203.61	4.2 mm Spring	1
41	60.2207.31	M8 Nut	1
42	60.2208.84	Spring Washer	1
43	16.2105.00	M5 x 6 mm Dowel	1
44	60.2252.31	Spring Nut	1
45	60.2253.31	Adjustment Nipple	1
46	11.4589.10	M8 Nut	1
47	16.1838.00	M4 Tc Screw	1
48	60.2251.84	Plastic Knob	1
49	14.3582.00	Washer, D 30 mm	1
50	60.2254.31	M30 Nut	1
51	29.0096.24	PR 5 pl. Housing Kit	1

***KIT 8.704-548.0 VB9.01+PR5 Spare Parts Kit, 14x1 pcs**

900/1400 3 PH W/ELEC IGNITION

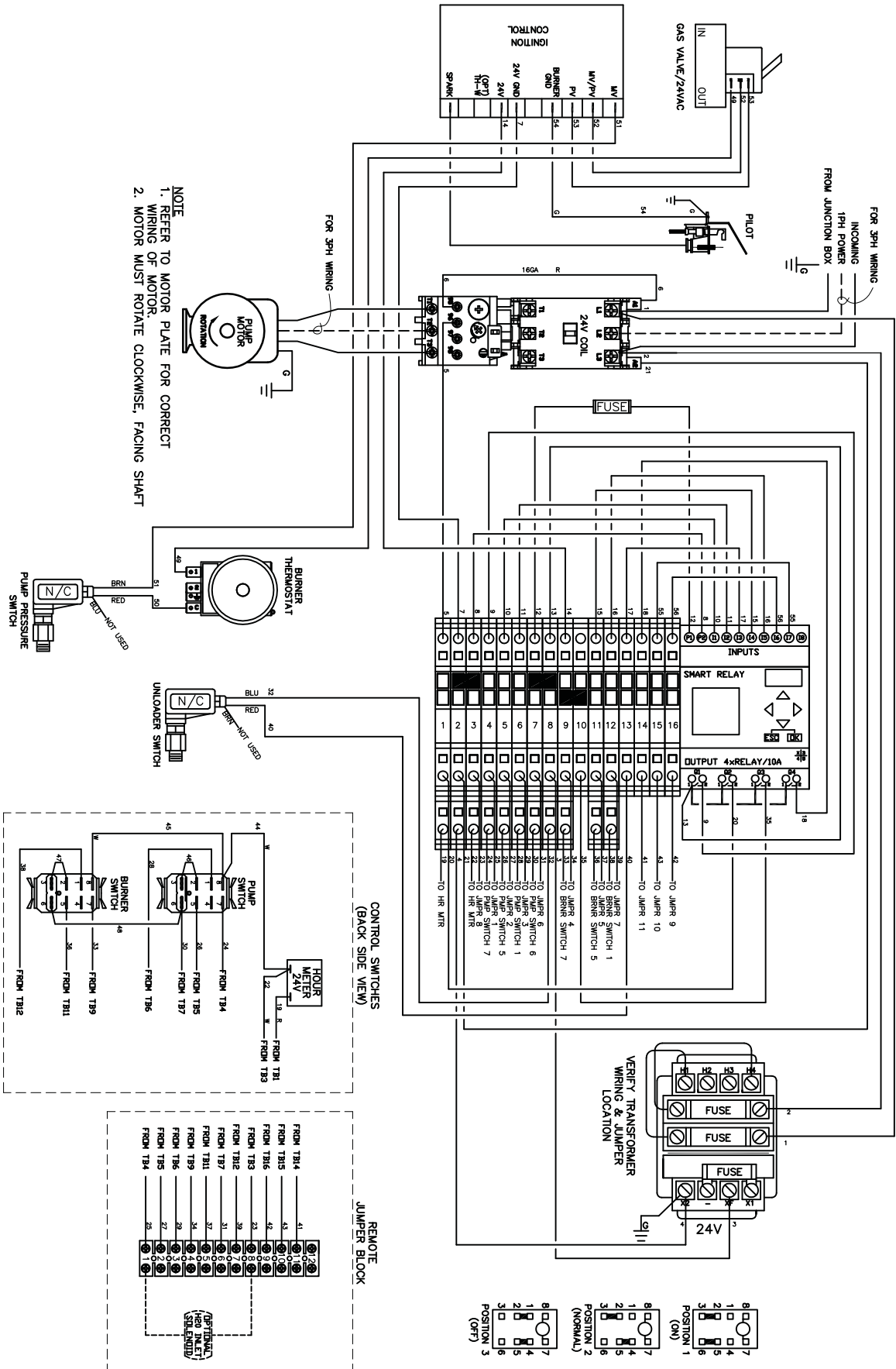

If you need **SERVICE** on your pressure washer, contact your local Hotsy dealer or visit www.Hotsy.com. Smart phone users scan the code below to link directly to the Service Request page.



To **REGISTER** your pressure washer, please visit our Warranty Registration page at www.hotsy.com/WarrantyRegistration.aspx or scan the code below with your smart phone.

